



# SRX712M 12" Two-Way Stage Monitor/Utility Speaker

## Professional Series

### Key Features:

- ▶ Compact and low-profile for minimal obstruction of audience sight-lines
- ▶ 90° x 50° nominal coverage
- ▶ Bi-amplified or full-range passive operation
- ▶ Dual-angle pole socket for applications requiring tripod mounting
- ▶ Optional yoke available for truss-mounted or suspended applications
- ▶ Neodymium magnet Differential Drive® woofer for high-power capacity and very light-weight
- ▶ 3" (diaphragm) neodymium magnet compression driver

### Applications

- ▶ Live performance stage monitoring
- ▶ Speech reinforcement
- ▶ Reinforcement of vocal and acoustic music
- ▶ High-performance satellite speaker for use with subwoofers

The SRX712M is a world-class, professional stage monitor. The SRX712M uses a JBL 2262H 305 mm (12 in) patented\* Differential Drive® woofer and a 2431H 75 mm (3 in) voice-coil, neodymium compression driver for 800 watts (continuous) power capacity from a monitor with a profile that is only 12 inches above the stage. A 50° x 90° aluminum horn provides smooth, even coverage whether the performer is standing right on the speaker or moving upstage.

Bi-amp or full-range passive operation may be selected by a recessed, high-current switch mounted in the handle cup. NL4 connectors are provided on both ends of the speaker to keep cable runs tidy on stage.

The SRX712M can also do double duty as a utility speaker. For use on a tripod or over a subwoofer, JBL's dual angle pole mount is included. This feature allows the speaker to be mounted in a vertical position or with a 10° down tilt for optimum audience coverage. If suspension or truss mounting is a requirement, add the optional SRX712M-YK yoke bracket. This accessory provides attachment points for a wide range of suspension and truss mounting hardware.

\*U.S. Patent 5,748,760; other U.S. and foreign patents pending.

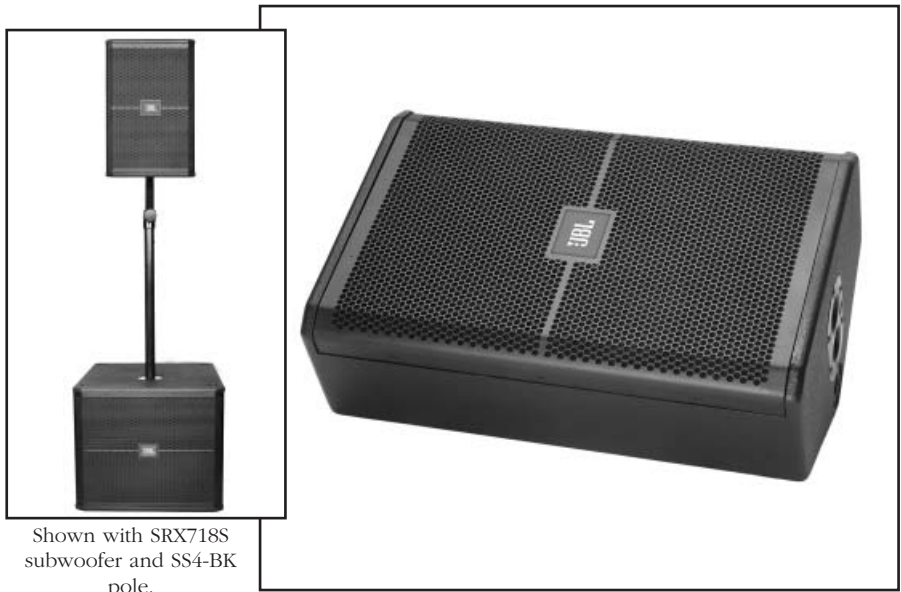

Shown with SRX718S subwoofer and SS4-BK pole.

The enclosure is constructed of top quality birch plywood and coated in JBL's rugged DuraFlex™ finish. The attractive CNC-machined, 16-gauge steel grille wraps around the sides of the enclosure so there are no protruding lips on the front of the box to create acoustical interference. The grilles are internally lined with acoustically transparent foam to provide additional driver protection and give a very professional appearance.

### Specifications:

System Type:	12", two-way, bass-reflex, stage-monitor / utility
Frequency Range (-10 dB):	70 Hz – 20 kHz
Frequency Response (±3 dB):	83 Hz – 18 kHz
Coverage Pattern:	50° x 90° nominal (Monitor position)
Crossover Modes:	Bi-amp / passive, externally switchable
Crossover Frequency:	1.2 kHz
Power Rating (Continuous <sup>1</sup> / Program / Peak):	Passive: 800 W / 1600 W / 3200 W Bi-amp LF: 800 W / 1600 W / 3200 W Bi-amp HF: 75 W / 150 W / 300 W
Maximum SPL <sup>2</sup> :	131 dB SPL peak
System Sensitivity (1w @ 1m):	96 dB SPL (passive mode)
LF Driver:	1 x JBL 2262H 305 mm (12 in) Differential Drive woofer
HF Driver:	1 x JBL 2431H 75 mm (3 in) voice coil, neodymium compression driver
Nominal Impedance:	Passive: 8 ohms Bi-amp LF: 8 ohms Bi-amp HF: 8 ohms
Active Tunings:	dbx DriveRack, all models. Settings available at <a href="http://www.jblpro.com">www.jblpro.com</a>
Enclosure:	Symmetrical stage monitor, 15 mm, 11-ply birch plywood.
Suspension / Mounting:	Dual-angle (0° or -10°), 35 mm pole socket 2 x M10 fittings for optional SRX712M-YK yoke
Transport:	Integrated handle / input cup
Finish:	Black DuraFlex finish
Grille:	Powder coated, black, 16-gauge perforated steel with acoustical transparent charcoal foam backing. Removable JBL badge and punched JBL logo.
Input Connectors:	Neutrik® Speakon® NL-4 (x2), one on each end
Dimensions (H x W x D):	349 mm x 546 mm x 260 mm (13.75 in x 21.5 in x 10.25 in)
Net Weight:	15 kg (33 lb)
Optional Accessories:	SRX712M-CVR: Pull-over padded cover SRX712M-YK: Suspension / mounting yoke

<sup>1</sup>IEC filtered noise with 6 dB crest factor.

<sup>2</sup>Calculated based on power rating and sensitivity.

JBL continually engages in research related to product improvement. Some materials, production methods and design refinements are introduced into existing products without notice as a routine expression of that philosophy. For this reason, any current JBL product may differ in some respect from its published description, but will always equal or exceed the original design specifications unless otherwise stated.

# SRX712M 12" Two-Way Stage Monitor/Utility Speaker

## Block Diagram

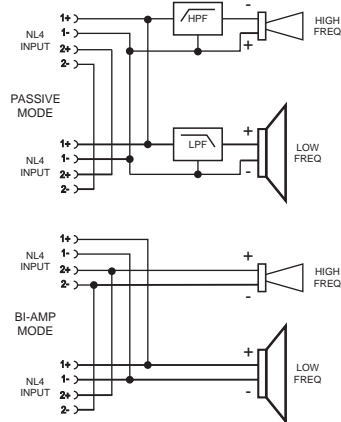
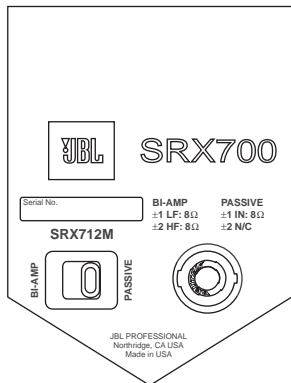

## Frequency Response

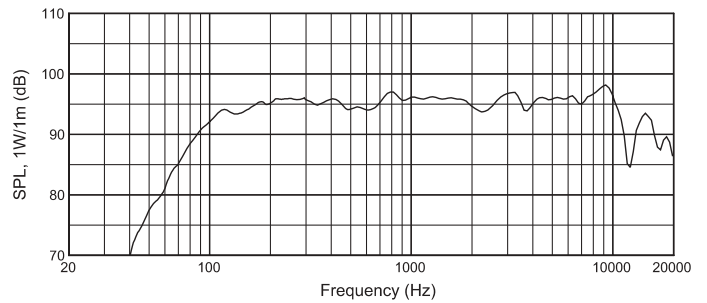

## Beamwidth

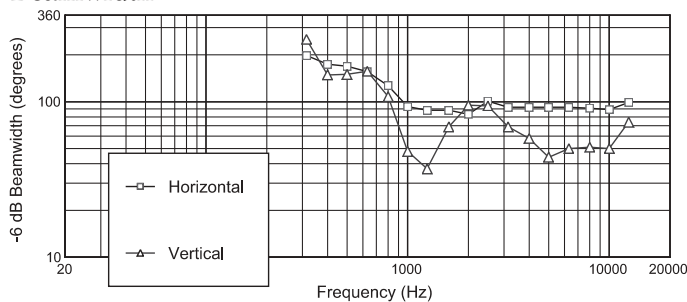

## Directivity Index

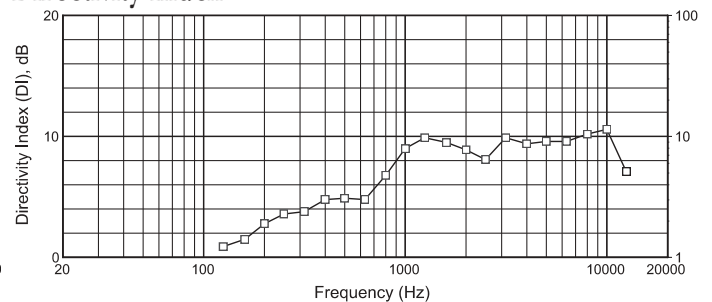

Graphs represent performance with passive crossover network

## Dimensions

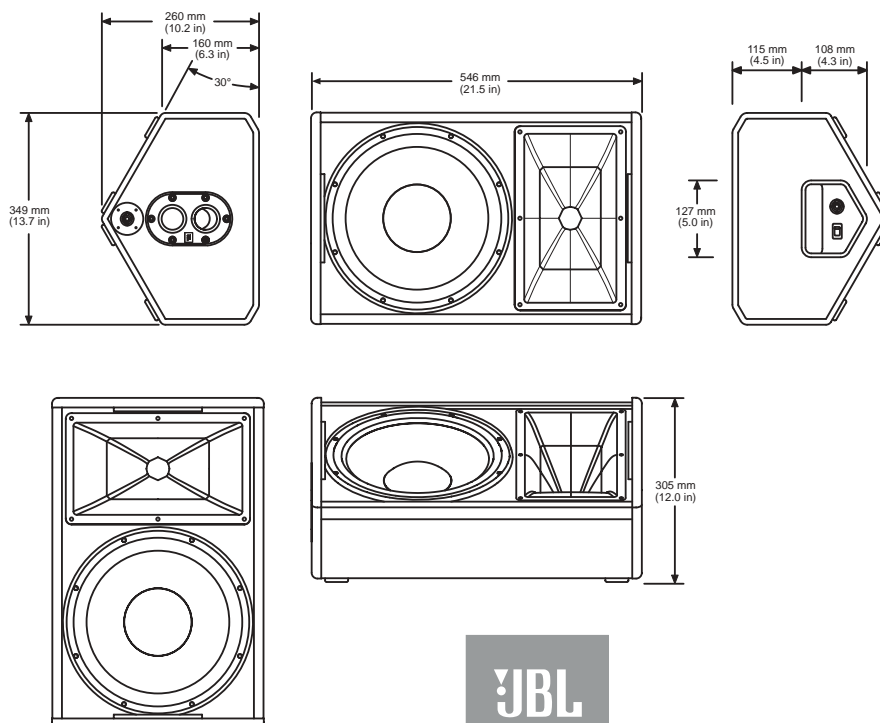

JBL Professional  
8500 Balboa Boulevard, P.O. Box 2200  
Northridge, California 91329 U.S.A.

A Harman International Company  
© Copyright 2004 JBL Professional

SS SRX712M  
CRP 5M  
08/04