

# ***DRAWMER***

## ***DA 6***

### **DISTRIBUTION AMP**

### **OPERATORS MANUAL**

#### **CONTENTS**

SAFETY CONSIDERATIONS	page 1
INTRODUCTION	page 2
INSTALLATION	page 2
HEADPHONES	pages 1, 4
ISOLATING TRANSFORMERS	page 3
CONTROL DESCRIPTIONS	page 6
IF A FAULT DEVELOPS	page 8
CONTACTING DRAWMER	page 8
TECHNICAL SPECIFICATION	page 9
BLOCK DIAGRAM	page 10

## **COPYRIGHT**

This manual is copyrighted © 2002 by Drawmer Electronics, Ltd. With all rights reserved. Under copyright laws, this manual may not be duplicated in whole or in part without the written consent of Drawmer.

## **ONE YEAR LIMITED WARRANTY**

Drawmer Electronics Ltd., warrants the Drawmer DA6 audio processor to conform substantially to the specifications of this manual for a period of one year from the original date of purchase when used in accordance with the specifications detailed in this manual. In the case of a valid warranty claim, your sole and exclusive remedy and Drawmer's entire liability under any theory of liability will be to, at Drawmer's discretion, repair or replace the product without charge, or, if not possible, to refund the purchase price to you. This warranty is not transferable. It applies only to the original purchaser of the product.

For warranty service please call your local Drawmer dealer. Alternatively call Drawmer Electronics Ltd. at +44 (0)1709 527574. Then ship the defective product, with transportation and insurance charges pre-paid, to Drawmer Electronics Ltd., Coleman Street, Parkgate, Rotherham, S62 6EL UK. Write the RA number in large letters in a prominent position on the shipping box. Enclose your name, address, telephone number, copy of the original sales invoice and a detailed description of the problem. Drawmer will not accept responsibility for loss or damage during transit.

This warranty is void if the product has been damaged by misuse, modification or unauthorised repair.

THIS WARRANTY IS IN LIEU OF ALL WARRANTIES, WHETHER ORAL OR WRITTEN, EXPRESSED, IMPLIED OR STATUTORY. DRAWMER MAKES NO OTHER WARRANTY EITHER EXPRESS OR IMPLIED, INCLUDING, WITHOUT LIMITATION, ANY IMPLIED WARRANTIES OF MERCHANTABILITY, FITNESS FOR A PARTICULAR PURPOSE, OR NON-INFRINGEMENT. PURCHASER'S SOLE AND EXCLUSIVE REMEDY UNDER THIS WARRANTY SHALL BE REPAIR OR REPLACEMENT AS SPECIFIED HEREIN.

IN NO EVENT WILL DRAWMER ELECTRONICS LTD. BE LIABLE FOR ANY DIRECT, INDIRECT, SPECIAL, INCIDENTAL OR CONSEQUENTIAL DAMAGES RESULTING FROM ANY DEFECT IN THE PRODUCT, INCLUDING LOST PROFITS, DAMAGE TO PROPERTY, AND, TO THE EXTENT PERMITTED BY LAW, DAMAGE FOR PERSONAL INJURY, EVEN IF DRAWMER HAS BEEN ADVISED OF THE POSSIBILITY OF SUCH DAMAGES.

Some states and specific countries do not allow the exclusion of implied warranties or limitations on how long an implied warranty may last, so the above limitations may not apply to you. This warranty gives you specific legal rights. You may have additional rights that vary from state to state, and country to country.

In the interests of product development, Drawmer reserve the right to modify or improve specifications of this product at any time, without prior notice.

# DRAWMER DA6

## Distribution Amp



### SAFETY CONSIDERATIONS



#### CAUTION - MAINS FUSE

TO REDUCE THE RISK OF FIRE REPLACE THE MAINS FUSE ONLY WITH THE SAME TYPE, WHICH MUST BE A CLASS 3, 230 VOLT, TIME DELAY TYPE, RATED AT 160mA WHERE THE MAINS INPUT VOLTAGE SWITCH IS SET TO 230 VOLTS AC. AND 315mA WHERE THE MAINS INPUT VOLTAGE IS 115 VOLTS AC. **ALL FUSES MUST COMPLY WITH BS EN 60127-2:1991, SHEET III.** THE FUSE BODY SIZE IS 20mm x 5mm.

#### CAUTION - MAINS CABLE

**DO NOT** ATTEMPT TO CHANGE OR TAMPER WITH THE SUPPLIED MAINS CABLE.

#### CAUTION - SERVICING

**DO NOT** PERFORM ANY SERVICING. REFER ALL SERVICING TO QUALIFIED SERVICE PERSONNEL.

#### WARNING

TO REDUCE THE RISK OF FIRE OR ELECTRIC SHOCK DO NOT EXPOSE THIS EQUIPMENT TO RAIN OR MOISTURE.

#### CAUTION - HEADPHONES

THE HEADPHONE AMPLIFIER IN THIS UNIT IS CAPABLE OF PRODUCING 1 WATT INTO 8Ω SPEAKERS. DRAWMER DO NOT ACCEPT ANY RESPONSIBILITY FOR DAMAGE CAUSED TO OPERATOR HEARING OR SPEAKER DEVICES BY USE OF EXCESSIVE OUTPUT LEVELS.

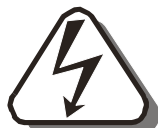

**CAUTION**  
**RISK OF ELECTRIC SHOCK**  
**DO NOT OPEN**



## INTRODUCTION

The distribution of mono and stereo balanced audio signals from a single source to multiple destinations has many applications, including: multi-zone sound reinforcement installation; live sports events coverage; broadcast studios; video suites; duplication houses or where high quality audio has to be distributed to a number of locations down long cable runs.

The Drawmer DA6 is a six channel stereo output ( or twelve mono ) distribution amplifier featuring XLR balanced connections. Optional transformer balanced outputs are offered for instances where electrical isolation of remote equipment is required.

The electronically balanced stereo input features individual left/right level controls with LED bargraph metering enabling the correct balancing of stereo material or two mono signals. Each of the six output pairs incorporate further left/right level controls and a Mono/Stereo switch which will mix two stereo signals, or, connect a single mono signal to both stereo outputs.

The monitor section consists of a channel select so that the individual left/right output level of each channel can be displayed on the output LED bargraph and can be simultaneously heard at the front-panel headphone jack.

An auxiliary pair of balanced output jacks provide a facility to connect further DA6 units where even more distribution is required. These outputs are post input gain trim, and may be fitted with optional output isolating transformers.

---

## INSTALLATION

The DA6 is designed for standard 19 " rack mounting and occupies 1U of rack space. Avoid mounting the unit directly above power amplifiers or power supplies that radiate significant amounts of heat. **Always** connect the mains earth to the unit. Use fibre or plastic washers to prevent the front panel becoming marked by the mounting bolts.

## AUDIO CONNECTIONS

Input and Output audio connections are provided via balanced XLRs at a level of +4dBu. This applies to both inputs and outputs. The wiring convention being:

Pin 1 Ground; pin 2 Hot; and pin 3 Cold.

For use with unbalanced systems, the Cold pin 3 must be grounded at both input and output inside the XLR connectors.

The Stereo Aux. Outputs are balanced ¼" (TRS) jack sockets, where Tip connection is Hot; Ring is Cold; and Sleeve is Ground. These connections are offered for chaining multiple DA6 units if there is a requirement for more than 6 stereo outputs. For use with unbalanced systems, use mono jack plugs, or connect the Ring (Cold) to the Sleeve terminal inside the Jack plugs.

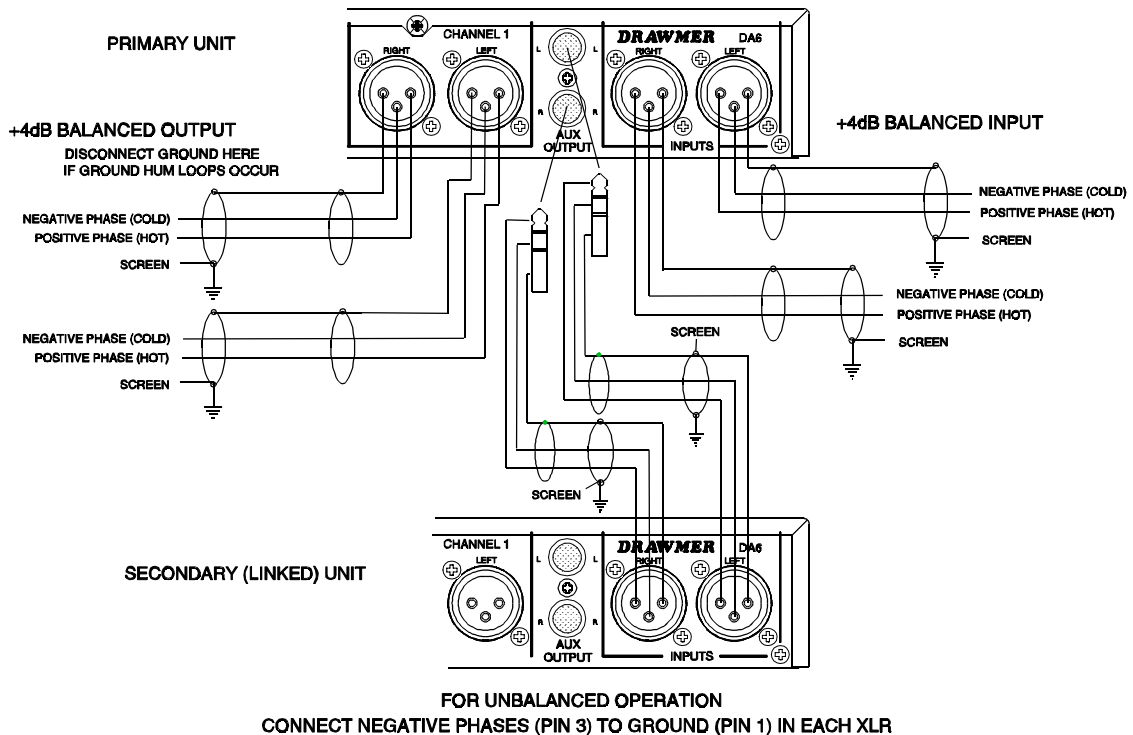

**Interference:** If the unit is to be used where it may be exposed to high levels of disturbance such as found close to a TV or radio transmitter, we suggest that the unit be operated using an optional wiring of the balanced configuration. The screens of the signal cables should be connected to the chassis connection on the XLR connector as opposed to connecting to pin 1. The DA6 fully conforms to the EMC standards.

**Ground Loops:** If ground loop problems are encountered, **never** disconnect the mains earth, but instead, try disconnecting the signal screen on one end of each of the cables connecting the DA6 to the patchbay. If such measures are necessary, balanced operation is recommended.

## ISOLATION TRANSFORMERS

The DA6 has the capability of being isolated at its outputs using low impedance (600Ω) balanced transformers. Each output can be individually isolated, and it is possible to have mixed configurations where some outputs retain their default connection of electronically balanced. Isolating transformers can be factory fitted, or alternatively, retro fitted by a Drawmer appointed service agent, or a suitably qualified engineer. The isolating transformer is manufactured by:

Stevens & Billington Ltd                      Part Number TX104

**Any warranty will be void if isolating transformers are fitted by non-approved methods, or, if unspecified transformers are fitted.**

---

## MONITOR HEADPHONES

For the purposes of monitoring each output, a stereo ¼" (TRS) jack socket is offered on the front panel. This having the standard wiring convention of Tip being Left; Ring being Right; and Sleeve being common Ground. This output is capable of driving headphones with an impedance between 8Ω and 600Ω. The amplifier has an output of approximately 1Watt. Caution is required when operating at high output levels with low impedance headphones.



DRAWMER do NOT accept any responsibility for damage caused to operator hearing or speaker devices by use of excessive output levels.

---

## POWER CONNECTION

The DA6 unit will be supplied with a power cable suitable for domestic power outlets in your country. For your own safety, it is important that you use this cable to connect to the mains supply earth. The cable must not be tampered with or modified.

The power supply socket has an integral fuse drawer containing the power fuse (and a spare) both of the same value, to suit the mains voltage for which the unit has been supplied. Removal of the drawer is only possible with the power cord removed. The fuse should never blow under normal operation. If the fuse is suspected of having blown, then a fault will have occurred and this fault condition should be inspected by a qualified service engineer. When replacing the fuse, always comply with the Safety Instructions.

If the unit is to be used with a mains input operating voltage different to that for which the unit is supplied, the following procedure must be carried out by a technically competent person, *(see following diagrams)*

- 1: Disconnect the unit from the mains.
- 2: Using a number 1 size pozidrive screwdriver, remove the seven self-tapping screws that retain the top cover. Two screws are found along each side; two along the top edge at the rear; and the upper central screw on the front fascia panel.
- 3: Slide the voltage change-over switch (**SW8**) until the correct (or nearest) mains input voltage is visible on the switch actuator.



# CONTROL DESCRIPTION

The DA6 has been designed for ease of use. It operates on balanced or unbalanced signal levels in the range -15dB to +15dB.(ref. +4dBm)

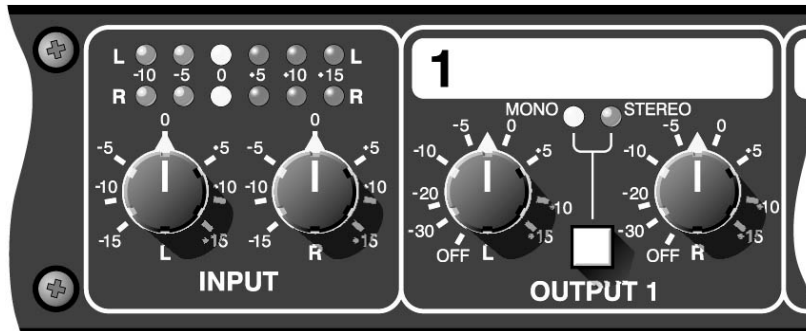

## Input L&R



Used to set the optimal input gain for both Left and Right signals. Use the display above to ensure the correct operating levels are being attained. Adjustment in the range  $\pm 15$ dB is possible. Separate controls are offered to permit the re-alignment of any offset stereo image.

These controls also adjust the output level of the auxiliary 'link' jacks, which implies that any connected slave DA6 will only require to have its input trims set to 0dB (vertically).

## Input Display

Since the DA6 is normally used as a line amplifier, then it is quite acceptable to 'see' signals in the positive gain region of this display. However, ensure that the +15dB LED never illuminates other than for brief instances, otherwise distortion will occur.

## Output L&R



These controls should be used to set the optimal output level to match the input section of the connected device, for both Left and Right signals. Adjustment of  $\pm 15$ dB is possible. Normally, any stereo image offset will have been corrected by the Left/Right input controls. However separate output controls are also offered to give total control of the stereo image.

## Mono/Stereo





Selects whether the channel output is to be separate Stereo signals or 'summed' to produce a Mono signal. If only one input is used, this will be output to both sockets if Mono is selected.



Caution should be used when operating the DA6 with two similar stereo signals that are out-of-phase with each other. Under such conditions, using the Mono mode will produce very little usable output. LEDs show the status of the switch.



- Chan Select**  This rotary switch selects which stereo (or mono) output is to be routed through to the stereo headphone amplifier.
- H/Phone**  This control determines the amount of headphone amplifier drive. Caution should be used when using high output levels and low impedance headphones.
- Output Display** This display shows the stereo output levels of the selected channel feed to headphones, removing the need to utilise headphones as a method of monitoring the output signals.
-

## IF A FAULT DEVELOPS

For warranty service please call Drawmer Electronics Ltd. Or their nearest authorised service facility, giving full details of the difficulty. On receipt of this information, service or shipping instructions will be forwarded to you. No equipment should be returned under the warranty without prior consent from Drawmer or their authorised representative.

For service claims under the warranty agreement a service Returns Authorisation (RA) number will be given. Write this RA number in large letters in a prominent position on the shipping box. Enclose your name, address, telephone number, copy of the original sales invoice and a detailed description of the problem.

Authorised returns should be prepaid and must be insured. All Drawmer products are packaged in specially designed containers for protection. If the unit is to be returned, the original container must be used. If this container is not available, then the equipment should be packaged in substantial shock-proof material, capable of withstanding the handling for the transit.

---

## CONTACTING DRAWMER

Drawmer Electronics Ltd., will be pleased to answer all application questions to enhance your usage of this equipment. Please address correspondence to:

Drawmer (Technical Help line) : Coleman St.: Parkgate : Rotherham : S62 6EL : UK

or, E-mail us on :

[tech@drawmer.com](mailto:tech@drawmer.com)

Drawmer dealers, Authorised service departments and other contact information can be obtained from our web pages on <http://www.drawmer.com>

---

# TECHNICAL SPECIFICATIONS

All Levels ref. +4dBm

<b>INPUT IMPEDANCE</b>	15K $\Omega$	
<b>MAX. INPUT LEVEL</b>	Bal. +23.5dB	Unbal. +18dB
<b>MAX. OUTPUT LEVEL</b>	Bal. +22.5dB (Any output)	Unbal. +17.5dB into 600 $\Omega$ .
<b>OUTPUT IMPEDANCE</b>	33 $\Omega$ (electronically balanced)	
<b>NOISE</b>	Better than -95 dB (Gain=0dB, Bandwidth 22Hz - 22kHz)	
<b>CROSSTALK</b>	Better than -90dB @ 10kHz (Input grounded, any channel output)	
<b>DISTORTION</b>	@ 1kHz	Output 0dB better than 0.008% +10dB better than 0.008% +20dB better than 0.015%
<b>BANDWIDTH</b>	18Hz to 32kHz -1dB	
<b>HEADPHONE AMPLIFIER</b>	Will deliver 1 Watt into 8 $\Omega$ Recommended Headphone Impedance 8 $\Omega$ to 600 $\Omega$	

## TRANSFORMER OPTION

Outputs fitted with specified Stevens & Billington Ltd transformer will have the following specification:-

Max. Input Level @ 40 Hz	+6dB for 0.5% THD.
Distortion @ 1 KHz	0 dB Output better than 0.008%
Bandwidth 10 K $\Omega$ Load	20 Hz - 45 KHz
Insertion Loss	0.10dB (with 10 K $\Omega$ load)
Bandwidth 600 $\Omega$ Load	20 Hz - 33 KHz
Insertion Loss	0.67dB (with 600 $\Omega$ load)
DCR Winding 1	6.9 $\Omega$ + 7.6 $\Omega$
DCR Winding 2	11.6 $\Omega$

**POWER REQUIREMENTS** 115Volt or 230Volt at 50-60Hz, 30 Watts

**FUSE RATING** 160mA for 230Volt, 315mA for 115Volt  
CONFORMING TO BS EN 60127-2:1991 SHEET III

**FUSE TYPE** 20mm x 5mm, Class 3 Slo-Blo, 250Volt Working

**CASE SIZE** 482mm (w) x 44mm (h) x 200mm (d)

**WEIGHT** (incl packaging) 4.05 Kgs. (With all Transformers fitted 4.60 Kgs.)

# BLOCK DIAGRAM

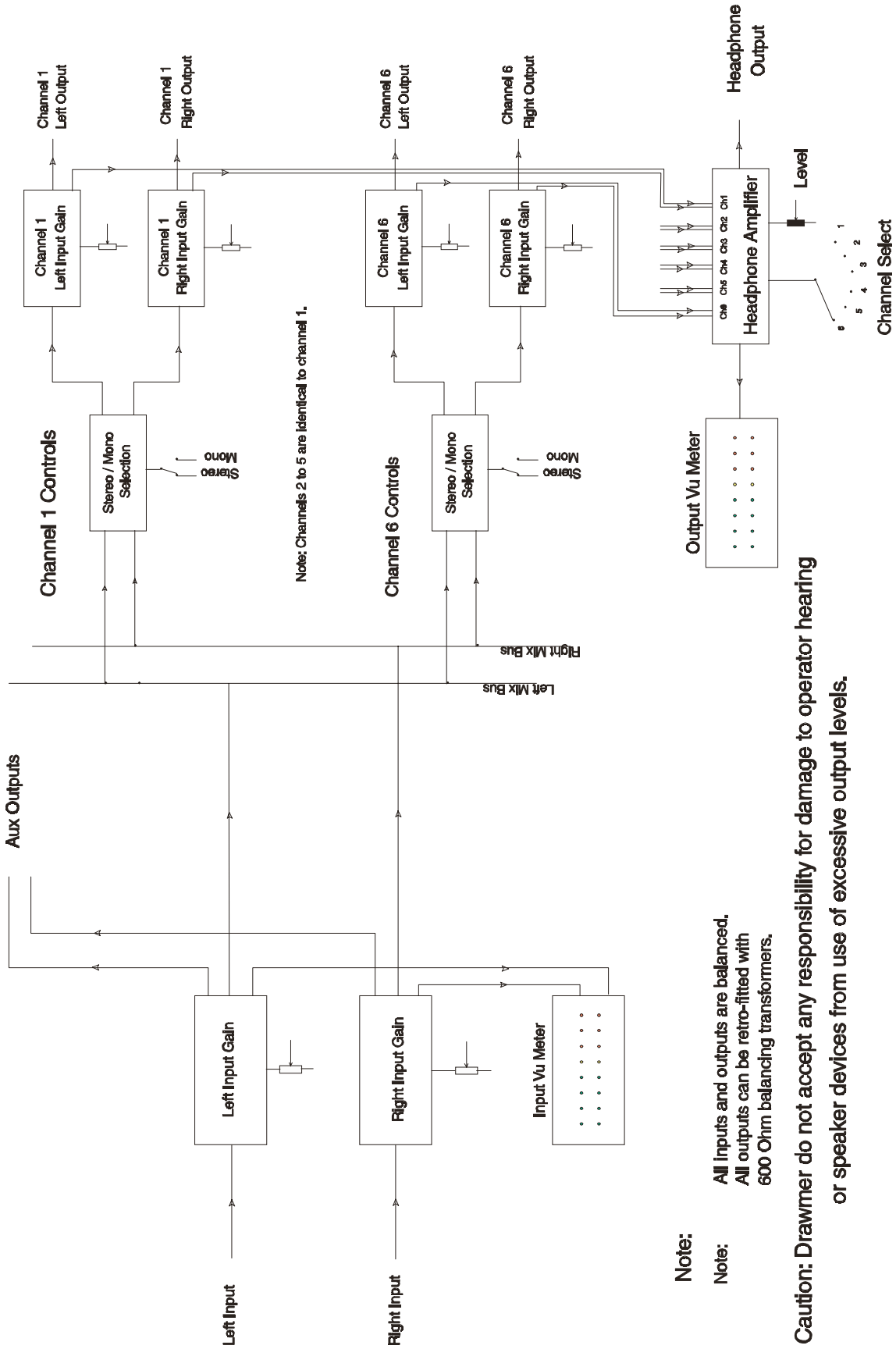

**Note:**

All inputs and outputs are balanced.  
All outputs can be retro-fitted with  
600 Ohm balancing transformers.

**Caution:** Drawer do not accept any responsibility for damage to operator hearing or speaker devices from use of excessive output levels.