

Thank you for selecting the KSM series from Shure.

Over 90 years of audio experience has contributed to making this one of the finest microphones available.

If you have any questions not answered in this guide, please contact Shure Applications Engineering at 847-600-8440, Monday through Friday, from 8:00 am to 4:30 pm, CST. In Europe, call 49-7262-92490. In Asia, call 852-2893-4290. Our web address is www.shure.com.

General Description

This premium side-address, cardioid condenser microphone features a large dual-diaphragm optimized for world-class vocal recording and performance applications. With a tailored frequency response and extensive internal and external pop filtering, the single-pattern, dual-diaphragm design of the KSM42 exhibits an exceptionally smooth frequency response and ultra-wide dynamic range. The KSM42 is the premier choice for capturing sophisticated and intimate vocal performances.

Features

- Highly consistent cardioid polar pattern creates a broad "sweet spot" and natural off-axis response
- Dual-diaphragm design with an active front, ultra thin (2.5 micron) 24-karat gold, low mass, 1-inch Mylar® diaphragm
- Passive back diaphragm delivers exceptional control of low frequency proximity effect
- Tailored low-frequency roll-off minimizes low frequency room noise

- Integrated three-stage mesh grille guards against wind and breath noise—magnetic pop filter attachment for additional pop protection
- Open cage ShureLock® rubber suspension shock mount with low-profile magnetic pop filter produces a natural space between performer and microphone
- Extremely low self noise for critical studio vocal recording
- Advanced preamplifier technology exhibits extremely low self-noise with superior dynamic range, transient response and ultra-low distortion for transparent recording
- Premium electronic components and gold-plated internal and external connectors
- Durable zinc die-cast housing and hardened low carbon steel grille
- Internal shock mount to reduce unwanted handling and stand noise

Performance Characteristics

- Consistent frequency response, irrespective of distance
- High output level
- Extensive pop filtering protection system (internal and external)
- High input SPL capability
- Ultra-low distortion
- Uniform polar response
- Superior common mode rejection and suppression of radio frequency interference.

Applications

The KSM42 is designed primarily for:

- Solo and backing vocals
- Voice-overs
- Speech

Secondary uses might include:

- Ensembles—choral or orchestral room ambiance pick-up
- Acoustic instruments—piano, guitar, and stringed instruments
- Wind instruments—brass and woodwinds

Operation

Power Requirements

This microphone requires phantom power and performs best with a 48 Vdc supply (IEC-61938). However, it will operate with slightly decreased headroom and sensitivity with supplies as low as 11 Vdc.

Most modern mixers provide phantom power. You must use a **balanced** microphone cable: XLR-to-XLR or XLR-to-TRS.

Suspension Mount

Use the supplied ShureLock® rubber suspension mount to secure the microphone to a floor or boom stand.

Important: Thread the knurled locking ring securely to the base of the microphone. Do not overtighten.

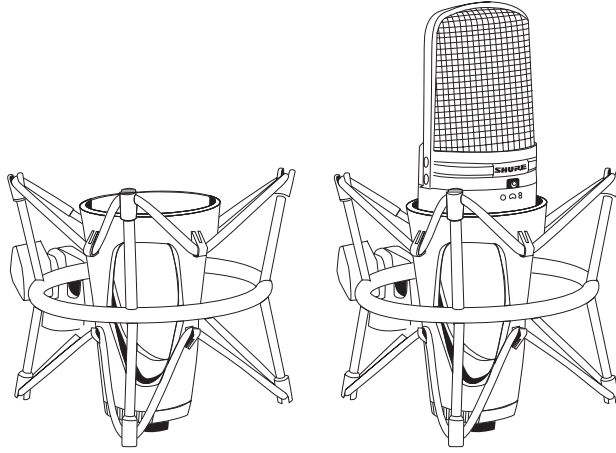

Positioning the Microphone

The front of the microphone is marked by the Shure logo. Position this side toward the sound source.

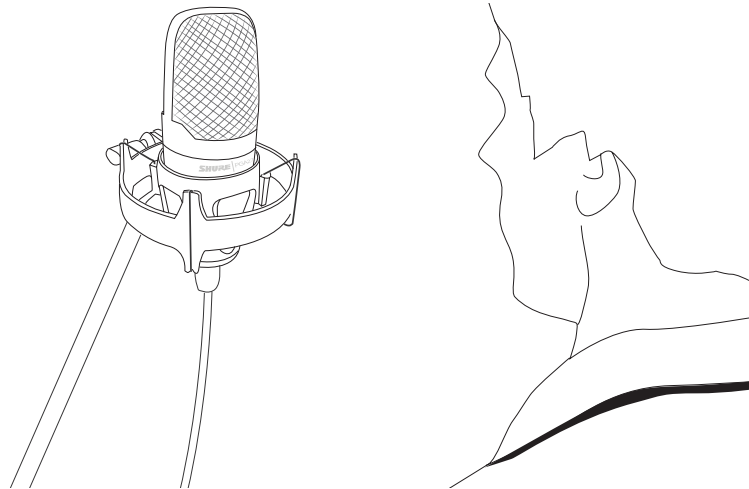

Pop Filter

An integrated three-stage mesh grille guards against wind and breath noise. Use the included pop filter accessory for additional protection against breath and "plosive" noises. The pop filter magnetically attaches to the front of the shockmount ring.

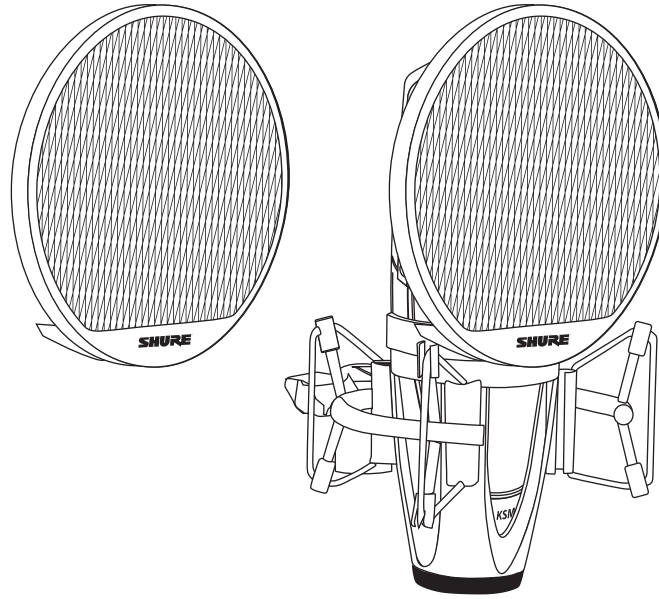

Reduction of Proximity Effect

To counter proximity effect, the KSM42 uses two diaphragms, one active and one passive, to create an acoustic phase shift at the rear of the microphone. This produces a broad "sweet spot" of uniform low-frequency response, allowing the performer to move closer or further from the microphone with minimal changes in sound quality.

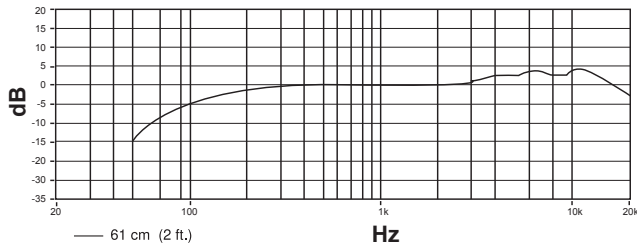

Vocalist at 2 feet

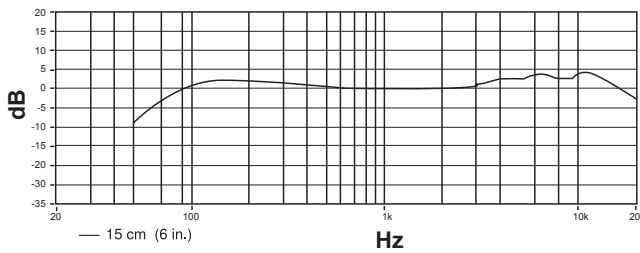
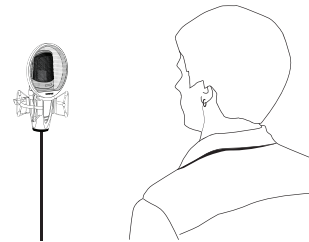

Vocalist at 6 inches



Specifications

Transducer Type

Dual-Diaphragm, Front-Active, Externally-Biased Condenser

Polar Pattern

Cardioid

Frequency Response

60 to 20,000 Hz

Output Impedance147 Ω **Sensitivity**

open circuit voltage, @ 1 kHz, typical

-37 dBV/Pa[1] (14.1 mV)

Maximum SPL

1 kHz at 1% THD[2]

2500 Ω load	139 dB
1000 Ω load	139 dB

Signal-to-Noise Ratio[3]

86 dB

Dynamic Range

@ 1 kHz

2500 Ω load	131 dB
1000 Ω load	131 dB

Clipping Level

20 Hz to 20 kHz, 1% THD

2500 Ω load	8.0 dBV
1000 Ω load	6.5 dBV

Self Noise

equivalent SPL, A-weighted, typical

8.5 dB SPL-A

Common Mode Rejection

10 to 100,000 kHz

 ≥ 60 dB**Connector**

Three-pin professional audio (XLR), male, balanced

Polarity

Positive pressure on diaphragm produces positive voltage on pin 2 with respect to pin 3

Power Requirements

11–52 V DC[4] phantom power (IEC-61938), 6 mA

Net Weight

494 g with shock mount and pop filter: 820 g

0 1 2 3

0 [1] 1 Pa=94 dB SPL

1 [2] THD of microphone preamplifier when applied input signal level is equivalent to cartridge output at specified SPL

2 [3] S/N ratio is the difference between 94 dB SPL and equivalent SPL of self noise, A-weighted

3 [4] All specifications measured with a 48 Vdc phantom power supply. The microphone operates at lower voltages, but with slightly decreased headroom and sensitivity.

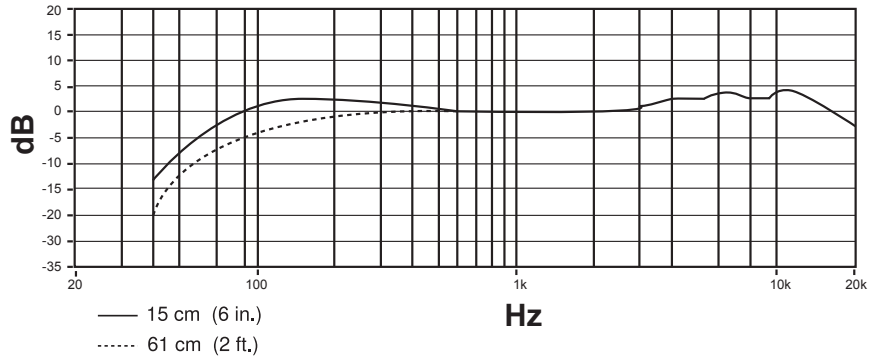

Typical Frequency Response

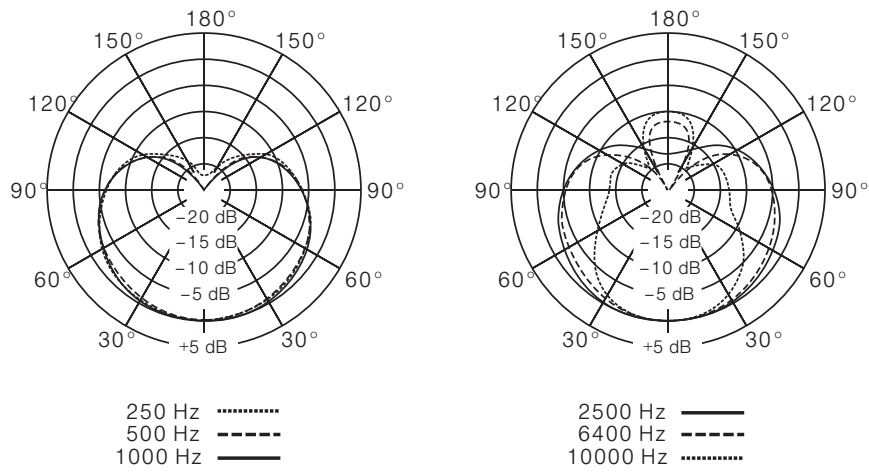

Typical Polar Patterns

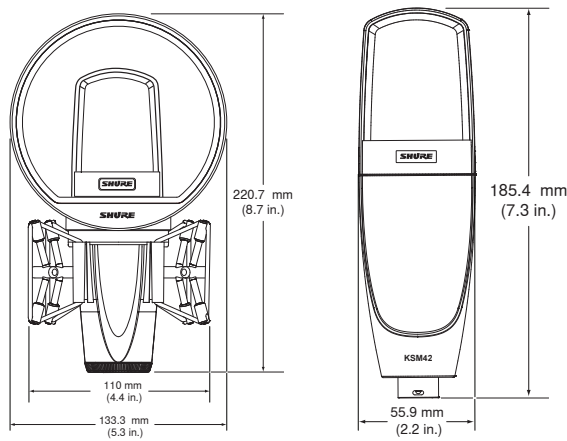

Overall Dimensions

Accessories

Furnished Accessories

PopperStopper™ Magnetic Pop-Filter for A42SM	A42PF
ShureLock® Shock Mount for KSM42	A42SM
Carrying Case	AK42C
Velveteen Pouch for KSM42	A42VB
Replacement O Rings for KSM42 Shock Mount (4)	A42OR

Optional Accessories

Black Foam Windscreen for BETA27, KSM27, KSM32, KSM42, KSM44, KSM44A, PG27, PG42 and SM27 Black Foam Windscreen for BETA 27, KSM27, KSM32, KSM42, KSM44, KSM44A, PG27, PG42 and SM27	A32WS
Padded Zippered Carrying Bag for KSM32	A32ZB
Black Mount/Swivel Adapter for BETA27, KSM27, KSM32 and KSM44 Black Mount/Swivel Adapter for Beta 27, KSM27, KSM32 and KSM44	A32M

Replacement Parts

Replacement O Rings for KSM42 Shock Mount Replacement O Rings for KSM42 Shock Mount (4)	A42OR
--	-------

Certifications

This product meets the Essential Requirements of all relevant European directives and is eligible for CE marking.

The CE Declaration of Conformity can be obtained from:
www.shure.com/europe/compliance

Authorized European representative:
Shure Europe GmbH

Headquarters Europe, Middle East & Africa
Department: EMEA Approval
Jakob-Dieffenbacher-Str. 12
75031 Eppingen, Germany
Phone: +49-7262-92 49 0
Fax: +49-7262-92 49 11 4
Email: info@shure.de

Trademark Notices: The circular S logo, the stylized Shure logo, the word "Shure," and "ShureLock" are registered trademarks of Shure Incorporated in the United States. "Popper Stopper" is a trademark of Shure Incorporated in the United States. "Mylar" is a registered trademark of E.I. DuPont de Nemours and Company in the United States. These marks may be registered in other jurisdictions.

Patent Notice: Pat. D447,131