

# Soka

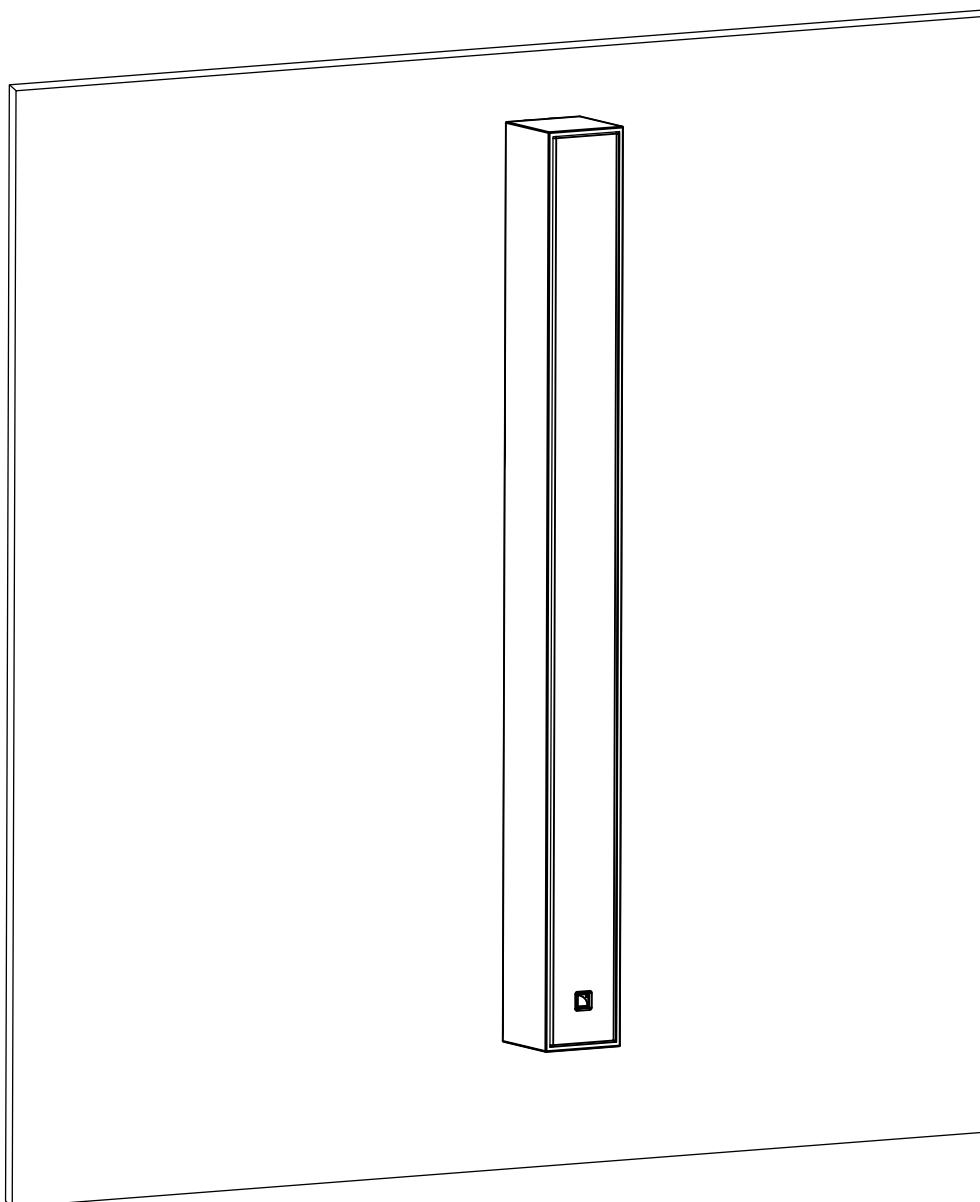

owner's manual (EN)



Document reference: Soka owner's manual (EN) version 1.0

Distribution date: June 5, 2023

© 2023 L-Acoustics. All rights reserved.

No part of this publication may be reproduced or transmitted in any form or by any means without the express written consent of the publisher.

## Contents

Safety.....	5
Instructions.....	5
Introduction.....	7
Soka ultra-shallow colinear source.....	7
How to use this manual.....	7
Revision history.....	8
System components.....	8
Electro-acoustical description.....	10
Directivity.....	10
Preset description.....	11
Connectors.....	11
Rigging system description.....	13
Soka.....	13
Soka-onW.....	14
Mechanical safety.....	15
Loudspeaker configurations.....	16
Soka colinear source.....	16
Soka ultra-shallow colinear source with low-frequency element.....	17
Soka with SB6i.....	17
Soka with SB10i.....	20
Rigging procedures.....	23
Tools.....	23
Wall-mounting with Soka-onW.....	23
Connection to LA amplified controllers.....	28
Cabling schemes for Soka.....	28
Cabling Soka.....	30
Specifications.....	33
Soka.....	33
SB6i.....	35
SB10i.....	36
Soka-onW.....	38







APPENDIX A: Recommendation for speaker cables..... 39

APPENDIX B: Specifications for custom rigging.....40

# Safety

## Instructions

---

-  **Inspect the system before any deployment.**  
Perform safety related checks and inspections before any deployment.
- Perform preventive maintenance at least once a year.**  
Refer to the preventive maintenance section for a list of actions and their periodicity.  
Insufficient upkeep of the product can void the warranty.
- If any safety issue is detected during inspection, do not use the product before performing corrective maintenance.**  
Check for issues. A rigging system part or fastener is missing or loose. A rigging system part exhibits: bends, breaks, broken parts, corrosion, cracks, cracks in welded joints, deformation, denting, wear, holes. A safety cue or label is missing.
-  **Never incorporate equipment or accessories not approved by L-Acoustics.**
-  **Read all the related PRODUCT INFORMATION documents shipped with the products before exploiting the system.**
-  **Do not store the product on an unstable cart, stand, tripod, bracket, or table.**
-  **Beware of sound levels.**  
Do not stay within close proximity of loudspeakers in operation.  
Loudspeaker systems are capable of producing very high sound pressure levels (SPL) which can instantaneously lead to permanent hearing damage to performers, production crew and audience members. Hearing damage can also occur at moderate level with prolonged exposure to sound.  
Check the applicable laws and regulations relating to maximum sound levels and exposure times.
-  **Work with qualified personnel for rigging the system.**  
Installation should only be carried out by qualified personnel that are familiar with the rigging techniques and safety recommendations outlined in this manual.
- Ensure personnel health and safety.**  
During installation and set-up personnel must wear protective headgear and footwear at all times. Under no circumstances is personnel allowed to climb on a loudspeaker assembly.
- Respect the Working Load Limit (WLL) of third party equipment.**  
L-Acoustics is not responsible for any rigging equipment and accessories provided by third party manufacturers. Verify that the Working Load Limit (WLL) of the suspension points, chain hoists and all additional hardware rigging accessories is respected.
- Respect the maximum configurations and the recommended safety precautions.**  
For safety issue, respect the maximum configurations outlined in this manual. To check the conformity of any configuration in regards with the safety precautions recommended by L-Acoustics, model the system in Soundvision and refer to the warnings in Mechanical Data section.
- Be cautious when flying a loudspeaker configuration.**  
Before installing/raising the product, check each individual element to make sure that it is securely fastened to the adjacent element. Always verify that no one is standing underneath the product when it is being installed/raised. Never leave the product unattended during the installation process.  
As a general rule, L-Acoustics recommends the use of secondary safety at all times.
- Be cautious when ground-stacking a loudspeaker array.**  
Do not stack the loudspeaker array on unstable ground or surface. If the array is stacked on a structure, platform, or stage, always check that the latter can support the total weight of the array.  
As a general rule, L-Acoustics recommends the use of safety straps at all times.

**Risk of falling objects**

Verify that no unattached items remain on the product or assembly.

**Risk of tipping**

Remove all rigging accessories before transporting a product or an assembly.

**Take into account the wind effects on dynamic load.**

When a loudspeaker assembly is deployed in an open air environment, wind can produce dynamic stress to the rigging components and suspension points.

If the wind force exceeds 6 bft (Beaufort scale), lower down and/or secure the product or the assembly.

**Intended use**

This system is intended for use by trained personnel for professional applications.



**As part of a continuous evolution of techniques and standards, L-Acoustics reserves the right to change the specifications of its products and the content of its documents without prior notice.**

Check [www.l-acoustics.com](http://www.l-acoustics.com) on a regular basis to download the latest document and software updates.

**Long term exposure to extreme conditions may damage the product.**

For more information, refer to the **Products weather protection** document, available on the website.

**Read the maintenance section of this document before servicing the product.****Contact L-Acoustics for advanced maintenance.**

Any unauthorized maintenance operation will void the product warranty.



This marking indicates that this product should not be disposed of with other household waste throughout the EU. To prevent possible harm to the environment or human health from uncontrolled waste disposal, recycle it responsibly to promote the sustainable reuse of material resources. To return your used device, please use the return and collection systems or contact the retailer where the product was purchased. They can take this product for environmentally safe recycling.



# Introduction

## Soka ultra-shallow colinear source

---

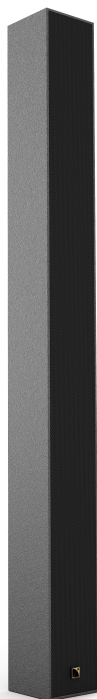

Soka is a colinear source system suited to medium throw applications that require discretion and elegance. Inheriting from our line source systems, Soka brings high fidelity and live concert power to high- end architectural and professional sound reinforcement settings, with minimal visual impact.

As a passive enclosure, Soka features nine 3.5" neodymium LF speakers and three 1" neodymium HF compression drivers, loaded by DOOSC waveguides in a J-shaped progressive curvature. This transducer arrangement, called colinear source, produces a H/V directivity pattern of 140° x 26° (+5/-21°), optimized for ultra-wide horizontal coverage with extended throw capability and controlled vertical dispersion.

Soka can be driven using different presets to match specific acoustic needs or coupling configurations with subwoofers. A broadband preset provides extension down to 60 Hz and 124 dB of SPL. For vocal reinforcement, or when closely coupled with a subwoofer, such as SB6i or SB10i, Soka can be driven with the 100 or 200 Hz presets, offering very-high output of 130 dB or 133 dB respectively.

The unique combination of discrete form factor and performance makes Soka ideal for vocal reinforcement or surround systems when used on its own. Accompanied by a subwoofer, Soka is also an ideal main music system in museums, commercial, residential, luxury settings, hospitality spaces, and more.



This owner's manual is intended for on-wall configurations with the Soka enclosure only. For in-wall configurations, refer to the **Sokar owner's manual**.

## How to use this manual

---

The Soka owner's manual is intended for all actors involved in the system design, implementation, preventive and corrective maintenance of the Soka system. It must be used as follows:

1. Read the technical description for an overview of all system elements, their features, and their compatibilities.
  - [Electro-acoustical description](#) (p.10)
  - [Rigging system description](#) (p.13)
2. Prepare the system configuration. Consider the mechanical limits and the available acoustical configurations.
  - [Mechanical safety](#) (p.15)
  - [Loudspeaker configurations](#) (p.16)
3. Before rigging the system, perform mandatory inspections and functional checks.
4. To deploy the system, follow the step-by-step rigging instructions and refer to the cabling schemes.
  - [Rigging procedures](#) (p.23)
  - [Connection to LA amplified controllers](#) (p.28)

**As part of a continuous evolution of techniques and standards, L-Acoustics reserves the right to change the specifications of its products and the content of its document without prior notice.** Please check [www.l-acoustics.com](http://www.l-acoustics.com) on a regular basis to download the latest document and software updates.

## Contact information

For information on advanced corrective maintenance:

- contact your Certified Provider or your L-Acoustics representative

- for Certified Providers, contact the L-Acoustics customer service: [customer.service@l-acoustics.com](mailto:customer.service@l-acoustics.com) (EMEA/APAC), [laus.service@l-acoustics.com](mailto:laus.service@l-acoustics.com) (Americas).

## Symbols

The following symbols are used in this document:

 This symbol indicates a potential risk of harm to an individual or damage to the product. It can also notify the user about instructions that must be strictly followed to ensure safe installation or operation of the product.

 This symbol notifies the user about instructions that must be strictly followed to ensure proper installation or operation of the product.

 This symbol notifies the user about complementary information or optional instructions.

## Revision history

version number	publication date	modification
1.0	Jun. 2023	Initial version.

## System components

### Loudspeaker enclosures

Soka	2-way passive colinear enclosure: 9 × 3.5" LF + 3 × 1" HF diaphragm
SB6i	Ultra-shallow subwoofer: 2 × 6.5"
SB10i	Ultra-compact subwoofer: 1 × 10" (installation version)

### Powering and driving system

LA2Xi / LA4X / LA7.16i / LA12X	Amplified controller with DSP, preset library and networking capabilities
-----------------------------------	---

 Refer to the LA2Xi / LA4X / LA7.16i / LA12X owner's manual for operating instructions.

### Cables

2 × 2.5 mm <sup>2</sup> cable	speaker cable with bare wire endings Adapt the cable length to the installation.
custom 2-point speakON cable	2-point speakON cable (2.5 mm <sup>2</sup> gauge) to bare wire cable  This cable needs to be custom made.

 **Information about the connection of the enclosures to the LA amplified controllers is given in this document.**

Refer to the LA2Xi / LA4X / LA7.16i / LA12X owner's manual for detailed instructions about the whole cabling scheme, including modulation cables and network.

### Rigging elements

Soka-onW	On-wall mounting accessory for Soka
----------	-------------------------------------



## Software applications

Soundvision 3D acoustical and mechanical modeling software

LA Network Manager Software for remote control and monitoring of amplified controllers

**i** Refer to the **Soundvision** help.  
Refer to the **LA Network Manager** help.

## System component illustrations

---

### Cables

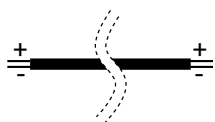

2 x 2.5 mm<sup>2</sup> cable

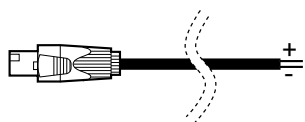

custom 2-point speakON cable

### Rigging accessories

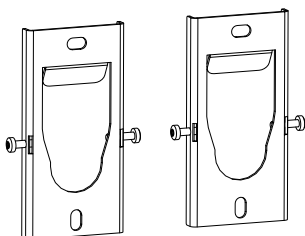

Soka-onW

### Software applications

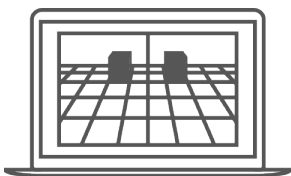

Soundvision



LA Network Manager

# Electro-acoustical description

## Directivity

Soka generates a horizontal directivity pattern of 140° and a vertical directivity pattern of +5°/-21° in J-shape (> 2 kHz).

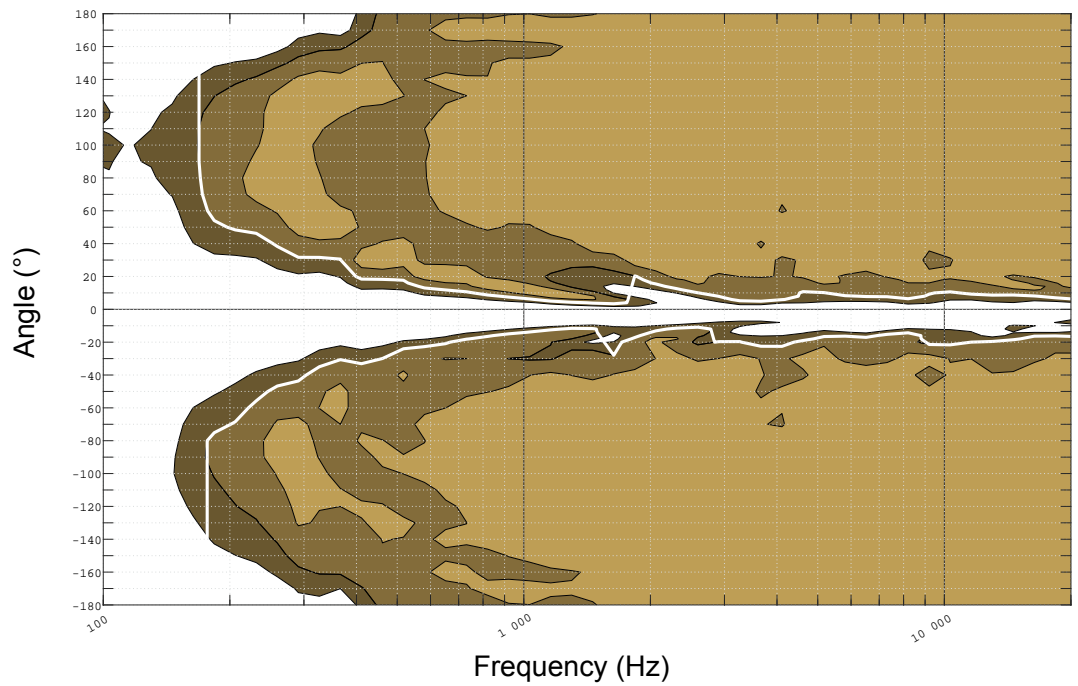
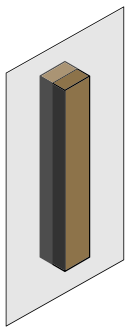
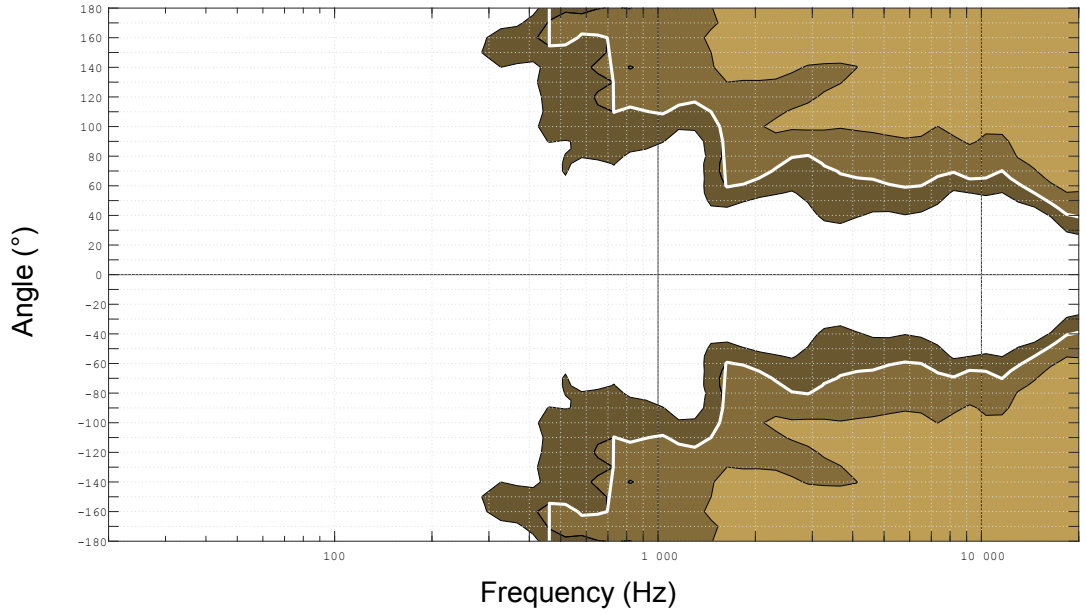
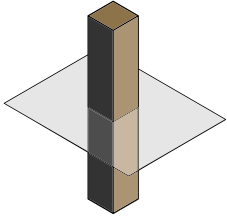

Dispersion angle diagram of a single enclosure, using lines of equal sound pressure at -3 dB, -6 dB, -12 dB.

## Preset description

[SOKA] [SOKA\_60] [SOKA\_200]

outputs	channels	routing	gain	delay	polarity	mute
OUT 1	PA	IN A	0 dB	0 ms	+	ON
OUT 2	PA	IN A	0 dB	0 ms	+	ON
OUT 3	PA	IN A	0 dB	0 ms	+	ON
OUT 4	PA	IN A	0 dB	0 ms	+	ON

[SB10\_60] [SB10\_100] [SB10\_200] [SB6\_60] [SB6\_100] [SB6\_200]

outputs	channels	routing	gain	delay	polarity	mute
OUT 1	SB	IN A	0 dB	0 ms	+	ON
OUT 2	SB	IN A	0 dB	0 ms	+	ON
OUT 3	SB	IN A	0 dB	0 ms	+	ON
OUT 4	SB	IN A	0 dB	0 ms	+	ON

## Connectors

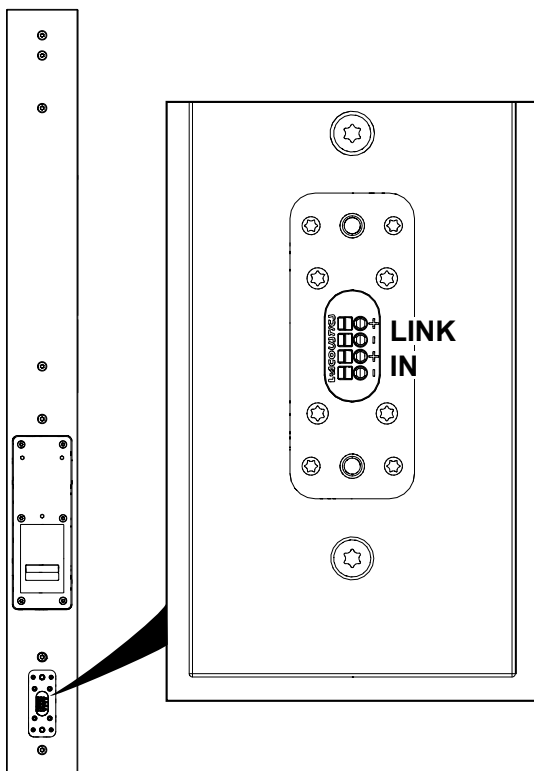

Soka is provided with a connector sealing plate with two cable glands for 2.5 mm<sup>2</sup> cables.

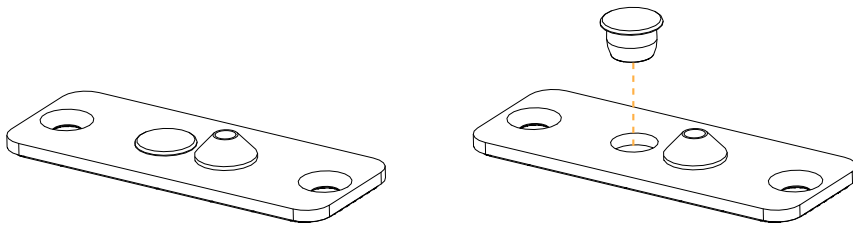

**!** Pass the cables through the cable glands before connecting them to the screw terminals.

Secure the connector sealing plate to protect the connector.

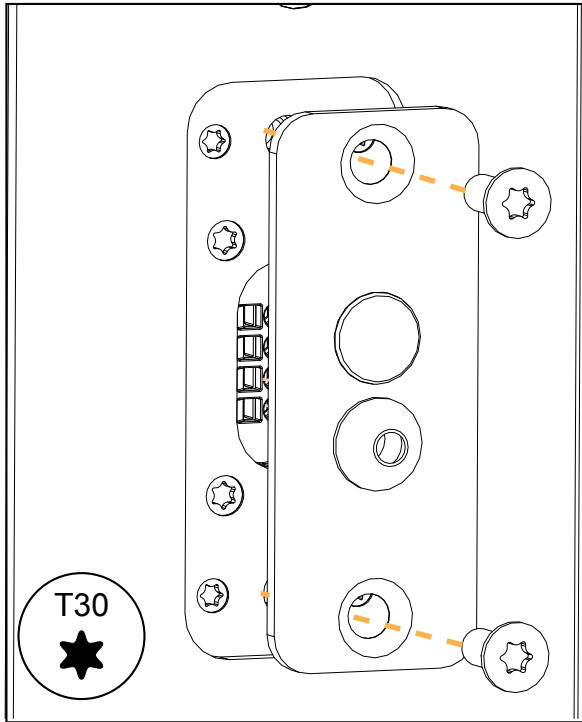

**Internal pinout for L-Acoustics 2-way passive enclosures**

Screw terminal points	IN +	IN -
Transducer connectors	+	-

## Rigging system description

### Soka

---

Soka is designed for on-wall configurations.

M6 inserts are available at the back of Soka to secure Soka-onW or compatible rigging accessories.

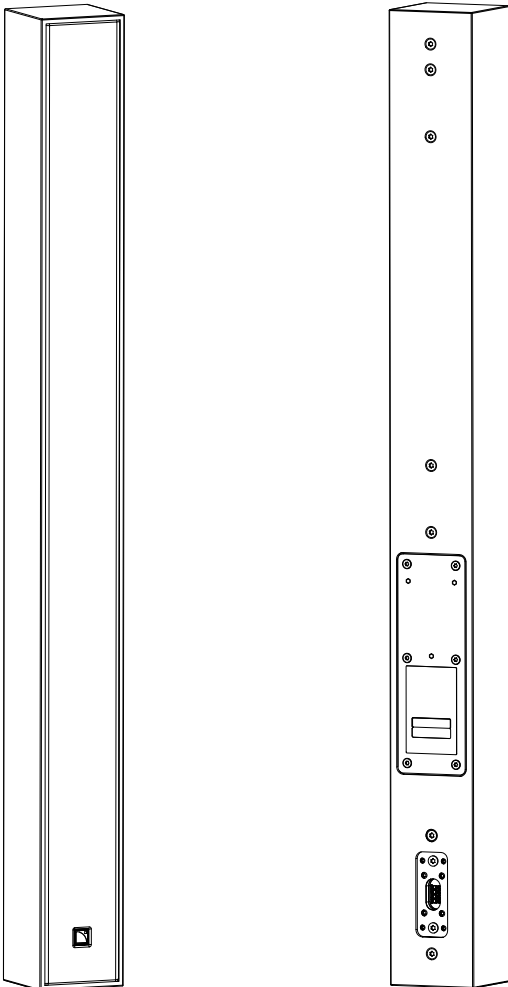

#### **Risk of acoustic leaks**

Always put the placeholder screws back in place when the inserts are not in use.

## Soka-onW

Soka-onW is a rigging interface with silent blocks for mounting one Soka on a wall in separated configurations. It is composed of:

- two surface-mounting plates
- two silent blocks
- fasteners for assembly and safety

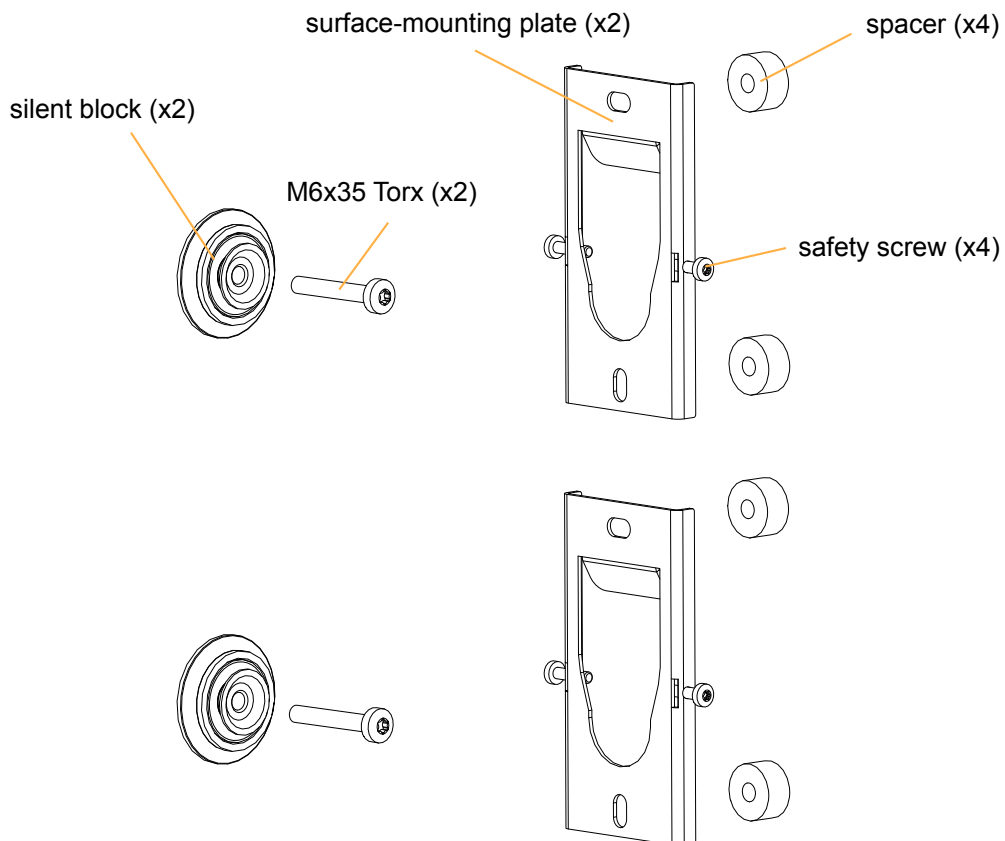

### Fasteners for wall-mounting

Secure the rigging element with four round or pan head M6 screws.  
Select screw length and anchors applicable to the wall properties.

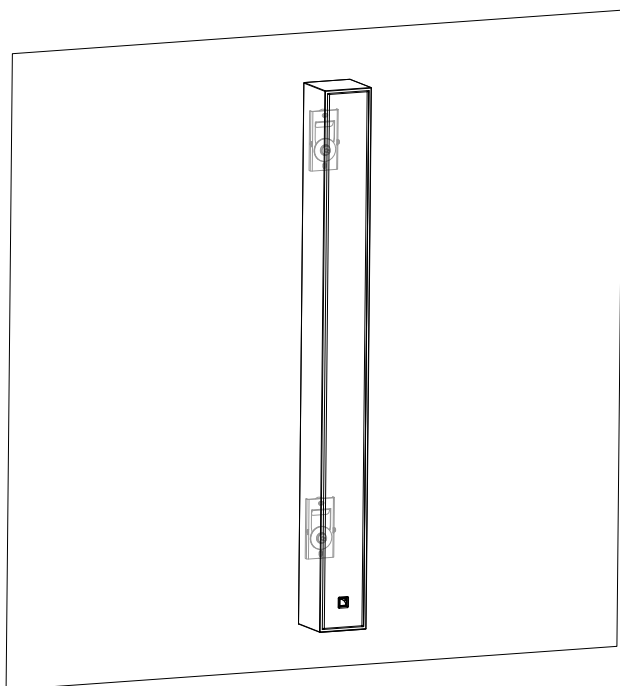

## Mechanical safety

The Soka rigging system complies with EN 62368-1: 2014 Audio/video, information and communication technology equipment – Part 1: Safety requirements.

The deployments described in this manual achieve a safety factor of **5**.

### Soka

<b>configuration</b>	<b>rigging accessory</b>	<b>safe limit / maximum limit</b>
wall-mounted	Soka-onW	1

## Loudspeaker configurations

### Soka colinear source

---

In this configuration the system operates over the nominal bandwidth of the enclosure.

The [SOKA] preset delivers a reference frequency response in medium throw applications.

The Soka enclosure is driven by the LA2Xi / LA4X / LA7.16i / LA12X amplified controllers.



Reduced maximum SPL or drive capacity with LA2Xi: refer to the **LA2Xi owner's manual**.



Enclosure	Soka
Preset	[SOKA]
Frequency range (-10 dB)	100 Hz - 20 kHz



#### Delay values

When combining a line source with subwoofers, delays may have to be added to the presets.  
Refer to the Preset Guide to obtain the pre-alignment delay values.



## Soka ultra-shallow colinear source with low-frequency element

Deployed as a colinear source with SB6i or SB10i subwoofers, Soka operates with augmented LF resources.

For closely coupled configurations, the [SOKA\_200] preset delivers a reference frequency response in medium throw applications, and the [SB6\_200] and [SB10\_200] presets provide SB6i and SB10i with an upper frequency limit at 200 Hz.

For coupled configurations, the [SOKA] preset delivers a reference frequency response in medium throw applications, and the [SB6\_100] and [SB10\_100] presets provide SB6i and SB10i with an upper frequency limit at 100 Hz.

For separated configurations, the [SOKA\_60] preset provides Soka with a lower frequency limit at 60 Hz, and the [SB6\_60] and [SB10\_60] presets provide SB6i and SB10i with an upper frequency limit at 60 Hz.

Soka, SB6i, and SB10i are driven by LA2Xi / LA4X / LA7.16i / LA12X.

### Soka with SB6i

#### Closely coupled

With SB6i and the preset [SB6\_200], the bandwidth of the Soka system is extended down to 32 Hz. The preset [SOKA\_200] provides optimal frequency coupling with the low-frequency element.

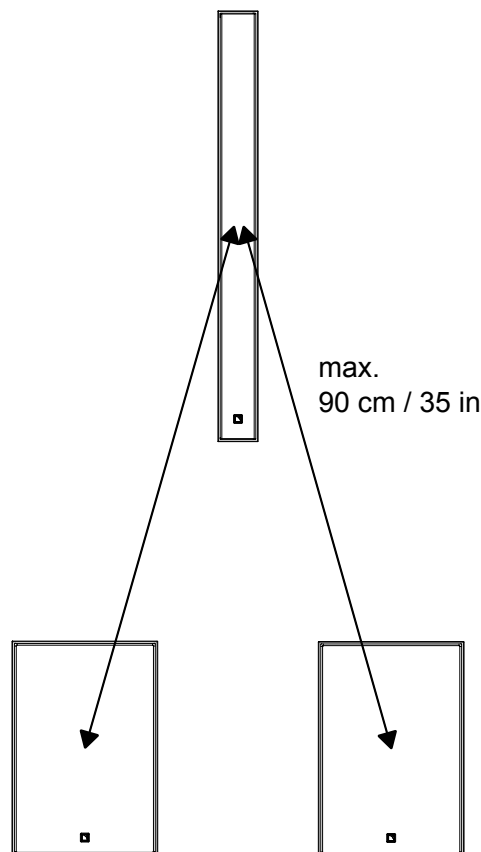

Enclosure	Soka	SB6i
Preset	[SOKA_200]	[SB6_200]
Ratio	1 Soka : 2 SB6i	
Low frequency limit (-10 dB)	32 Hz - 20 kHz	



#### Delay values

Do not forget to add the pre-alignment and geometric delays depending on the configuration.

### Pre-alignment delays

presets	pre-alignment delay values and polarity settings	
[SOKA_200] + [SB6_200]	Soka = 1.9 ms <input style="float: right;" type="button" value="+"/>	SB6i = 0 ms <input style="float: right;" type="button" value="+"/>

### Coupled

With SB6i and the preset [SB6\_100], the bandwidth of the Soka system is extended down to 29 Hz. The preset [SOKA] provides optimal frequency coupling with the low-frequency element.

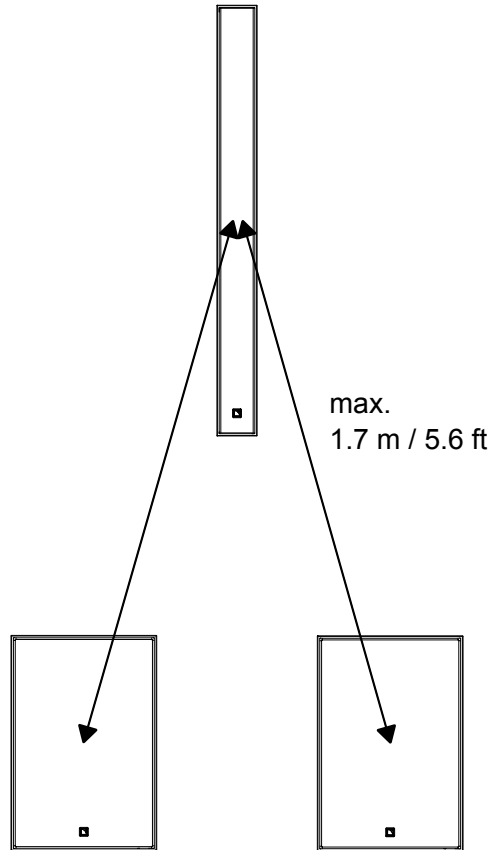

Enclosure	Soka	SB6i
Preset	[SOKA]	[SB6_100]
Ratio	1 Soka : 2 SB6i	
Low frequency limit (-10 dB)	29 Hz - 20 kHz	

### Delay values

Do not forget to add the pre-alignment and geometric delays depending on the configuration.

### Pre-alignment delays

presets	pre-alignment delay values and polarity settings	
[SOKA] + [SB6_100]	Soka = 1.4 ms <input style="float: right;" type="button" value="+"/>	SB6i = 0 ms <input style="float: right;" type="button" value="+"/>

## Separated

With SB6i and the preset [SB6\_60], the bandwidth of the Soka system is extended down to 29 Hz and the contour is reinforced by 6 dB\* at 50 Hz (peak low-end SPL). The preset [SOKA\_60] provides optimal frequency coupling with the low-frequency element.

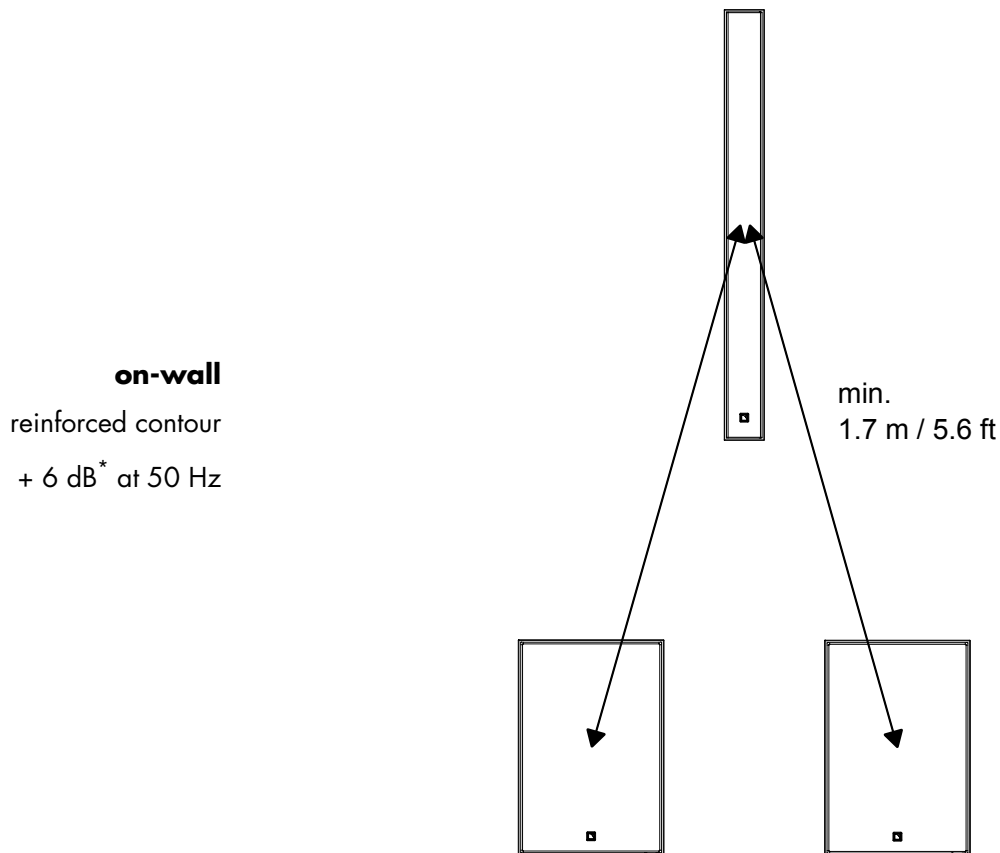

Enclosure	Soka	SB6i
Preset	[SOKA_60]	[SB6_60]
Ratio	1 Soka : 2 SB6i	
Low frequency limit (-10 dB)	29 Hz - 20 kHz	



### Delay values

Do not forget to add the pre-alignment and geometric delays depending on the configuration.

### Pre-alignment delays

presets	pre-alignment delay values and polarity settings	
[SOKA_60] + [SB6_60]	Soka = 3.6 ms <input style="float: right;" type="checkbox" value="+"/>	SB6i = 0 ms <input style="float: right;" type="checkbox" value="-"/>

\* Contour value takes into account the effect of the wall and floor on the contour.

## Soka with SB10i

### Closely coupled

With SB10i and the preset [SB10\_200], the bandwidth of the Soka system is extended down to 29 Hz and the system contour is reinforced by 4 dB\* at 50 Hz. The preset [SOKA\_200] provides optimal frequency coupling with the low-frequency element.

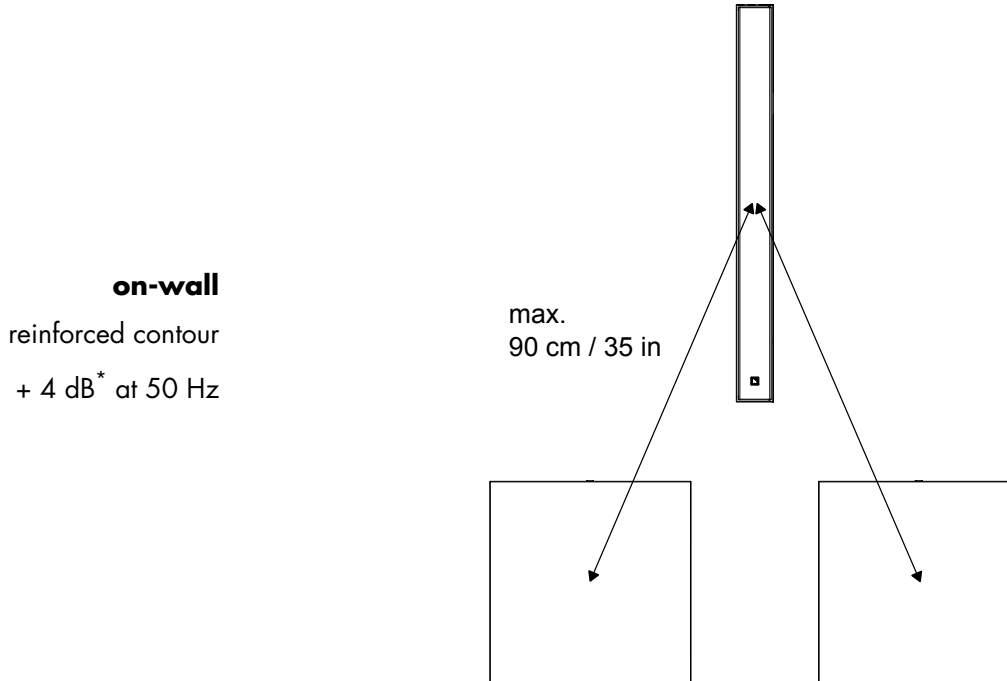

Enclosure	Soka	SB10i
Preset	[SOKA_200]	[SB10_200]
Ratio	1 Soka : 2 SB10i	
Low frequency limit (-10 dB)	29 Hz - 20 kHz	

### ! Delay values

Do not forget to add the pre-alignment and geometric delays depending on the configuration.

### Pre-alignment delays

presets	pre-alignment delay values and polarity settings	
[SOKA_200] + [SB10_200]	Soka = 3.2 ms <input type="checkbox"/>	SB10i = 0 ms <input type="checkbox"/>

\* Contour value takes into account the effect of the wall and floor on the contour.

## Coupled

With SB10i and the preset [SB10\_100], the bandwidth of the Soka system is extended down to 27 Hz and the system contour is reinforced by 4 dB\* at 50 Hz. The preset [SOKA] provides optimal frequency coupling with the low-frequency element.

**on-wall**  
reinforced contour  
+ 4 dB\* at 50 Hz

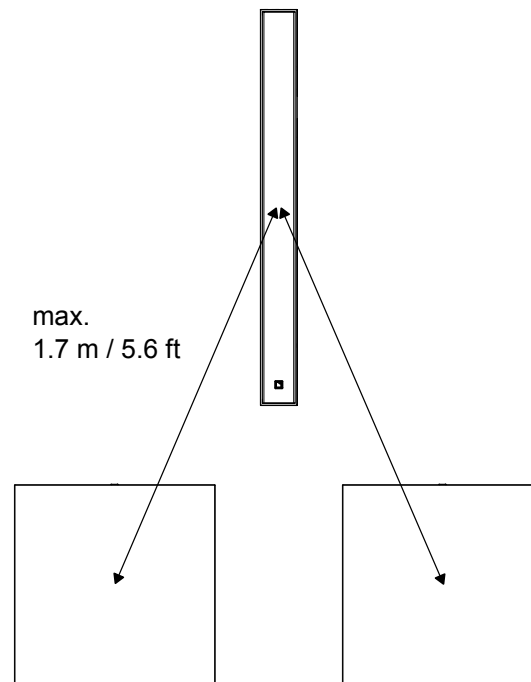

Enclosure	Soka	SB10i
Preset	[SOKA]	[SB10_100]
Ratio	1 Soka : 2 SB10i	
Low frequency limit (-10 dB)	27 Hz - 20 kHz	

### ! Delay values

Do not forget to add the pre-alignment and geometric delays depending on the configuration.

### Pre-alignment delays

presets	pre-alignment delay values and polarity settings	
[SOKA] + [SB10_100]	Soka = 2.6 ms <input type="checkbox"/>	SB10i = 0 ms <input type="checkbox"/>

\* Contour value takes into account the effect of the wall and floor on the contour.

### Separated

With SB10i and the preset [SB10\_60], the bandwidth of the Soka system is extended down to 25 Hz and the system contour is reinforced by 5 dB\* at 50 Hz. The preset [SOKA\_60] provides optimal frequency coupling with the low-frequency element.

**on-wall**  
reinforced contour  
+ 5 dB\* at 50 Hz

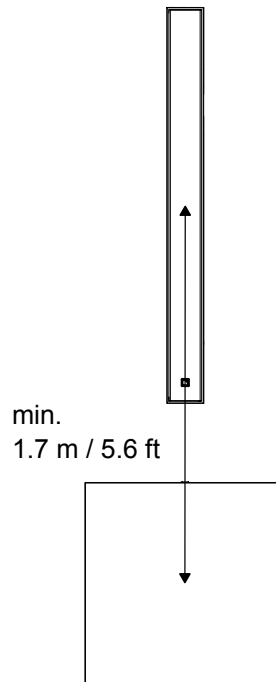

Enclosure	Soka	SB10i
Preset	[SOKA_60]	[SB10_60]
Ratio	1 Soka : 1 SB10i	
Low frequency limit (-10 dB)	25 Hz - 20 kHz	

### ! Delay values

Do not forget to add the pre-alignment and geometric delays depending on the configuration.

### Pre-alignment delays

presets	pre-alignment delay values and polarity settings	
[SOKA_60] + [SB10_60]	Soka = 9 ms <input style="float: right;" type="checkbox" value="+"/>	SB10i = 0 ms <input style="float: right;" type="checkbox" value="-"/>

\* Contour value takes into account the effect of the wall and floor on the contour.

## Rigging procedures

### Tools

Before rigging this product, make sure all the tools listed are available. References are given for FACOM® products in this table. Other manufacturers can be used.

name	reference	distributor
set of 6-point 1/4" sockets	RL.NANO1 / R.360NANO	FACOM
torque screwdriver (2 - 10 N.m)	A.404	FACOM

### Wall-mounting with Soka-onW

type of deployment	wall-mounting
rigging accessories	Soka-onW, including: <ul style="list-style-type: none"> <li>• 2 surface-mounting plates</li> <li>• 2 M6x35 Torx screws</li> <li>• 2 silent blocks</li> <li>• 4 spacers</li> </ul>
additional material	4 compatible screws and anchors
tools	torque screwdriver
	T30 Torx bit
	T20 Torx bit
min. number of operators	1



#### Fasteners for wall-mounting

Secure the rigging element with four round or pan head M6 screws.  
Select screw length and anchors applicable to the wall properties.

## Assembly

### Procedure



A paper drilling template of the rigging element is available in the box of the rigging element.

1. Prepare the wall for drilling.



Make sure to leave enough space between the walls and the sides of the rigging element to access the security screws when the enclosure is mounted.

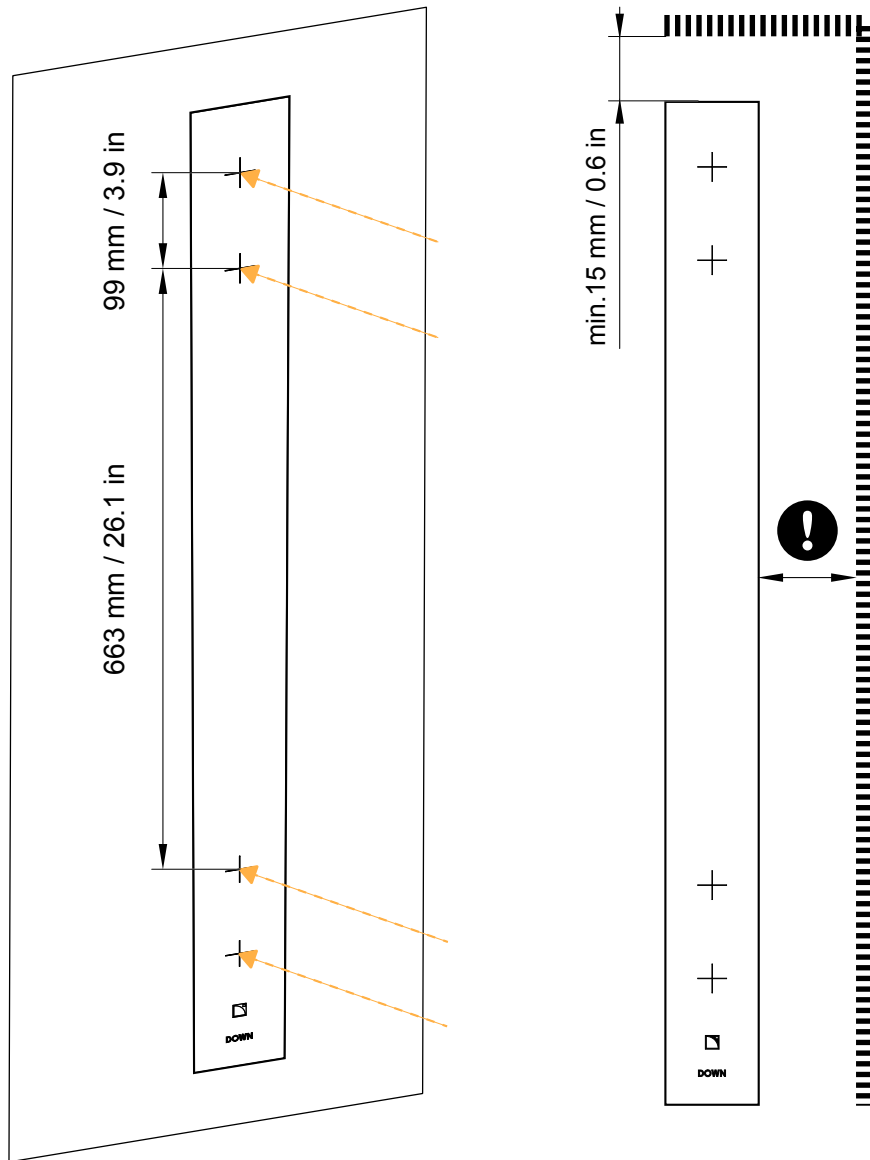



**2.** Secure the surface-mounting plate on the wall, using the four spacers.

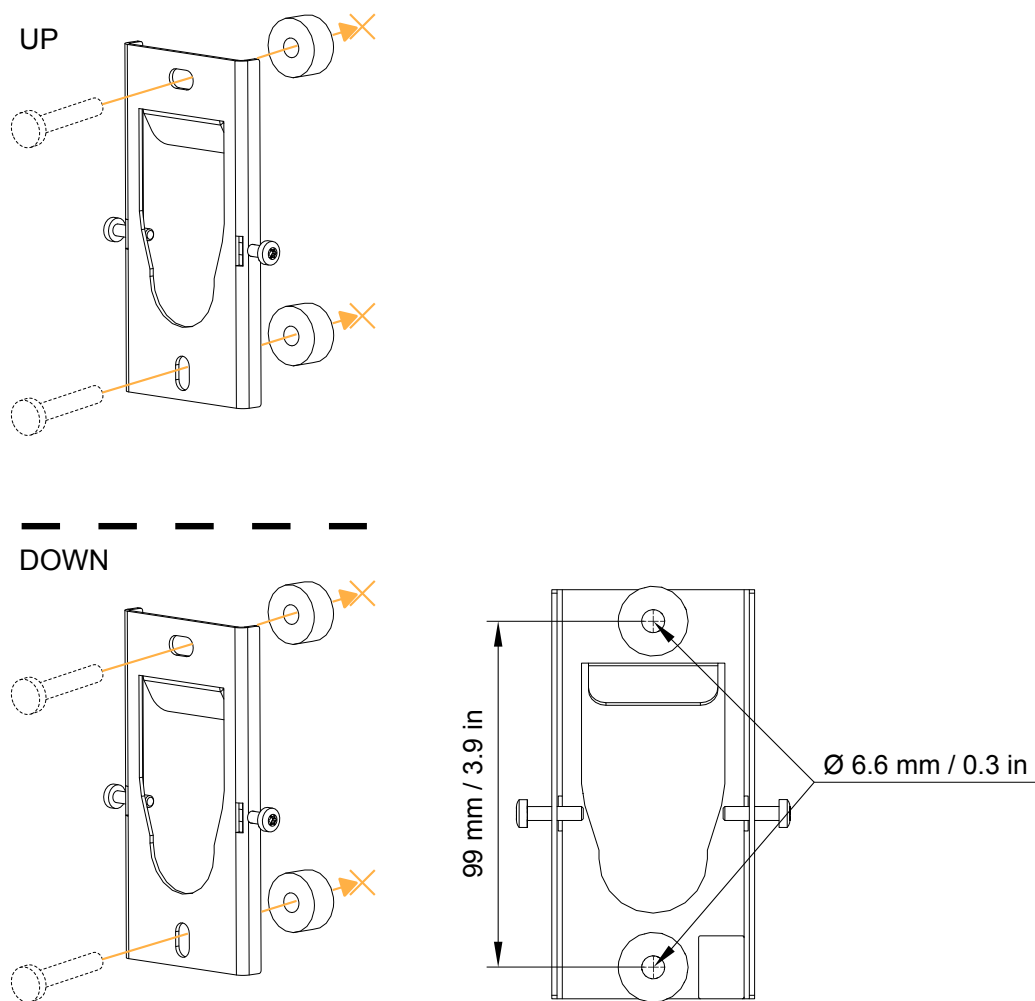

**3.** Remove the two placeholder screws from the back of Soka.

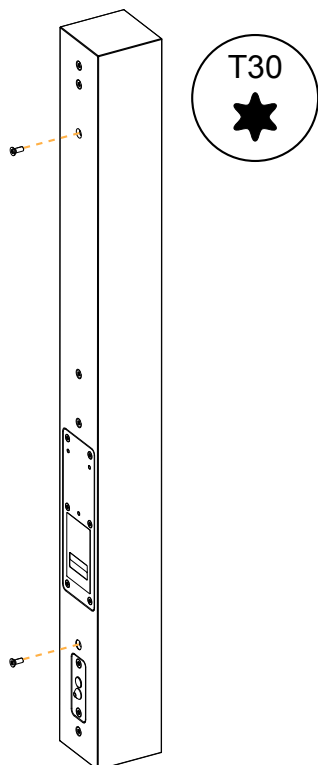

4. Mount the silent blocks to Soka with the two M6x35 Torx screws.

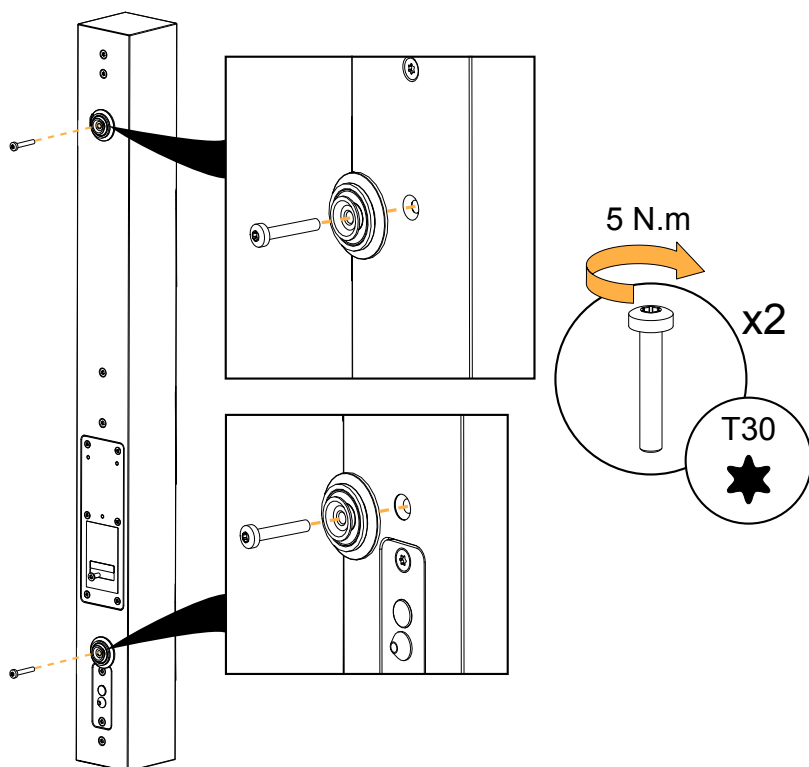

5. Prepare the cabling. Refer to [Cabling Soka](#) (p.30).
6. Mount the assembly on the surface-mounting plates.

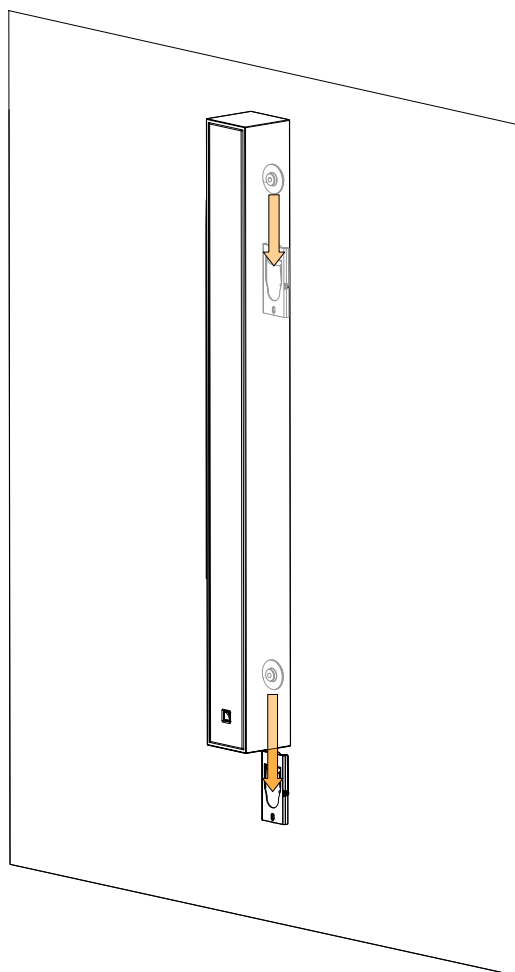

- 7.** Tighten the safety screws on both sides and make sure the assembly is stable.

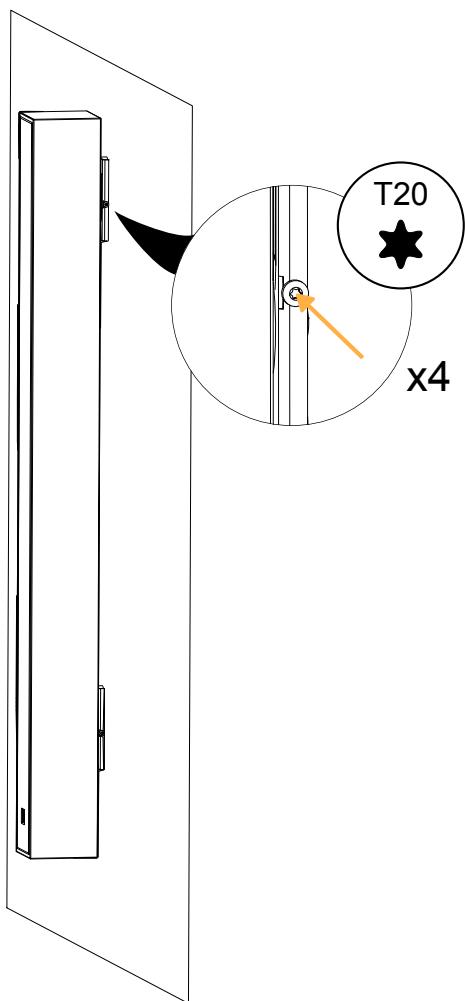

## Connection to LA amplified controllers

**!** Refer to the **Amplification reference** technical bulletin for the latest information on compatibility with amplified controllers and cabling schemes for all enclosure types.

### Enclosure drive capacity per amplified controller

Make sure the total number of connected enclosures does not exceed the maximum number of enclosures per controller (refer to the footnotes).

	LA2Xi	LA4X	LA7.16i	LA12X
	per output* / total	per output* / total	per output* / total	per output* / total
Soka	1 / 4 (SE), 1 / 2 (BTL)	2 / 8	1 / 16	3 / 12

**i** Reduced maximum SPL or drive capacity with LA2Xi: refer to the **LA2Xi owner's manual**.

## Cabling schemes for Soka

Refer to the cabling schemes to connect the enclosures to different types of output configurations.

**!** Refer to the cable manufacturer documentation for the wire color code.

### Terminal block output (LA2Xi SE / LA7.16i)

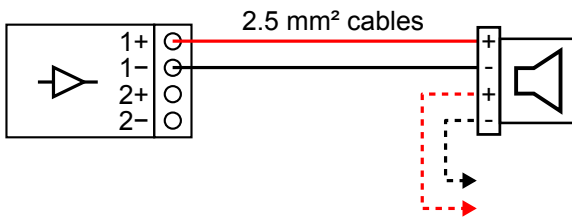

### Terminal block output (LA2Xi BTL)

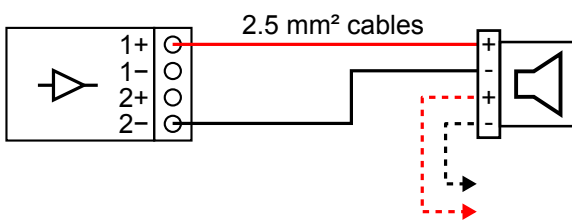

### One-channel speakON output

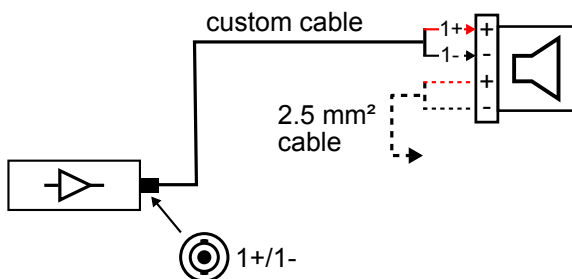

\* For passive loudspeakers, the value corresponds to the number of enclosures in parallel on the output. For active loudspeakers, the value corresponds to the number of sections in parallel on the output.

### Two-channel speakON output

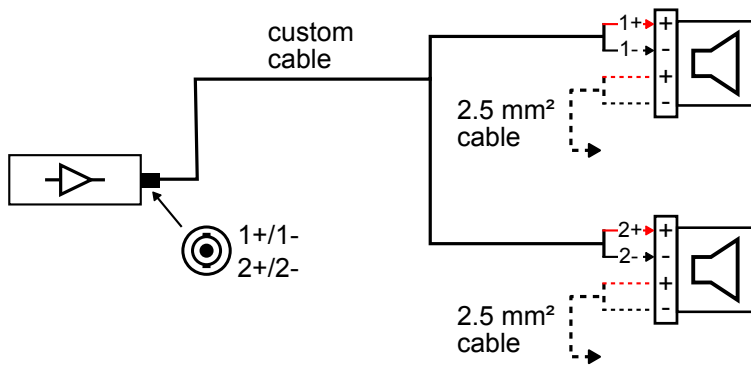

## Cabling Soka

<b>Accessory</b>	connector sealing plate (provided)
<b>Screws and fasteners</b>	2 M6×16 screws (mounted on enclosure)
<b>Tools</b>	torque screwdriver T30 Torx bit small tool or flat screwdriver (3 mm or less)
<b>Min number of operators</b>	1

## Assembly

### Prerequisite

**!** The cable glands on the connector sealing plate are compatible with cables up to 2 × 2.5 mm<sup>2</sup> gauge.

Refer to:

- [APPENDIX A: Recommendation for speaker cables](#) (p.39)
- [Cabling schemes for Soka](#) (p.28)

### About this task

The connector sealing plate has two holes: one for the input cable and one for the cable connecting to the next enclosure in parallel. By default, the first hole is fitted with a cable gland and the second one with a protective plug. An extra cable gland is provided with each enclosure.

This procedure describes how to connect the input cable to the enclosure. If the enclosure must be connected in parallel, replace the protective plug with the extra cable gland and proceed identically for both cables.

### Procedure

1. Remove the two screws from the enclosure.

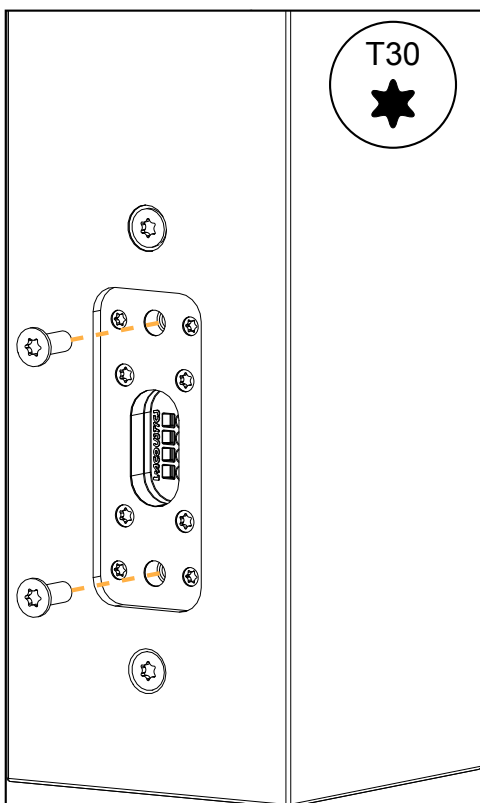

2. Insert the cable through the cable gland.

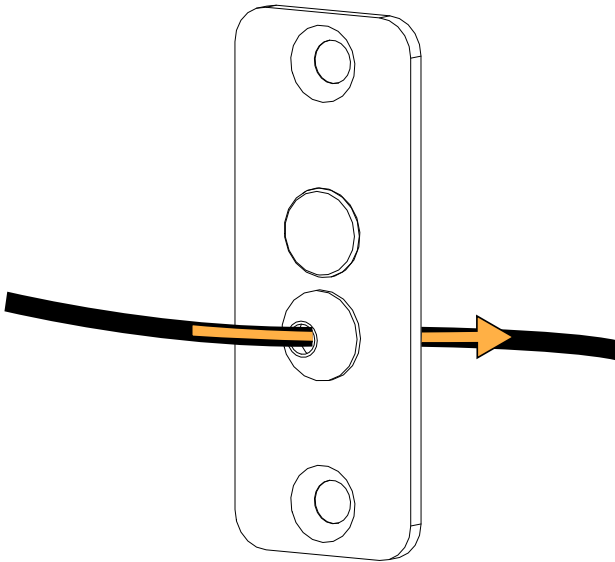

3. Strip the wires of the cable.

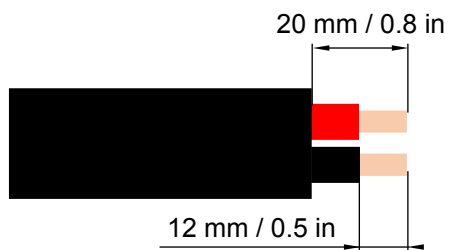

2 x max. 2.5 mm<sup>2</sup> cable

**!** Refer to the cable manufacturer documentation for the wire color code.

4. Push the wires into the terminals.

If necessary, use a small tool in the hole of the terminal to unlock it.

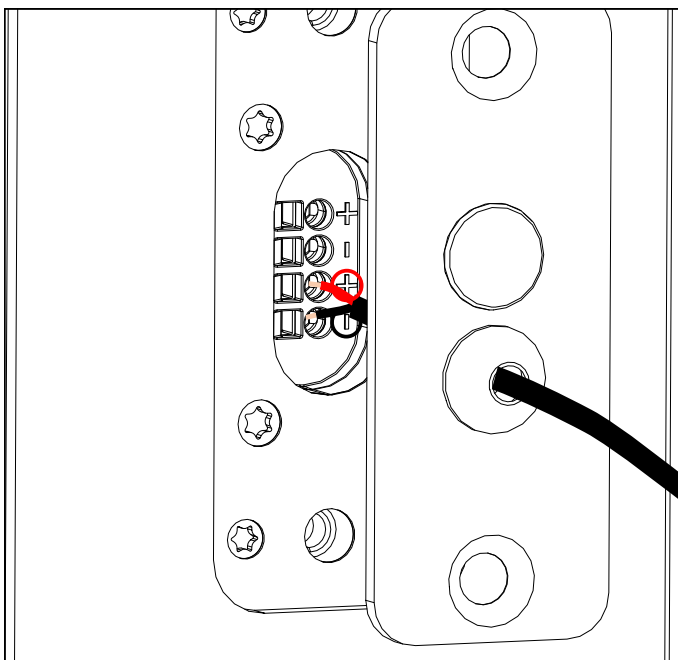

**5.** Secure the connector sealing plate to the enclosure.

Apply a torque of 3 N.m.

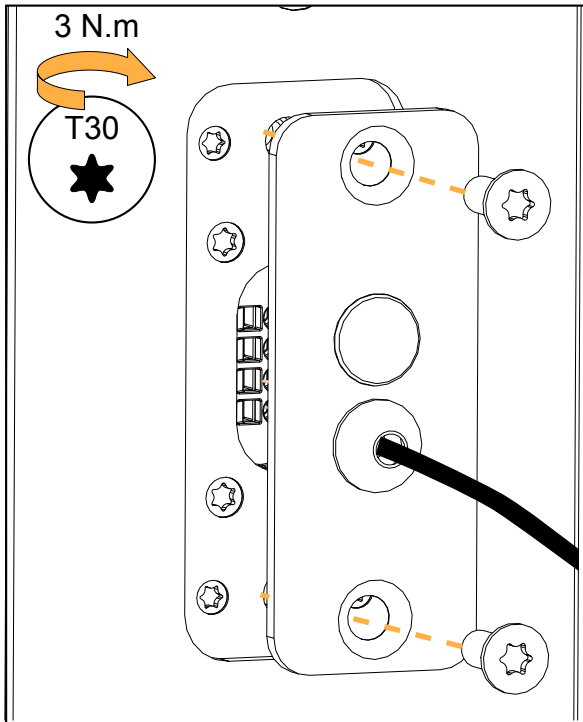

**What to do next**

To remove the cables, use the small tool to unlock the terminals and pull on the wires.

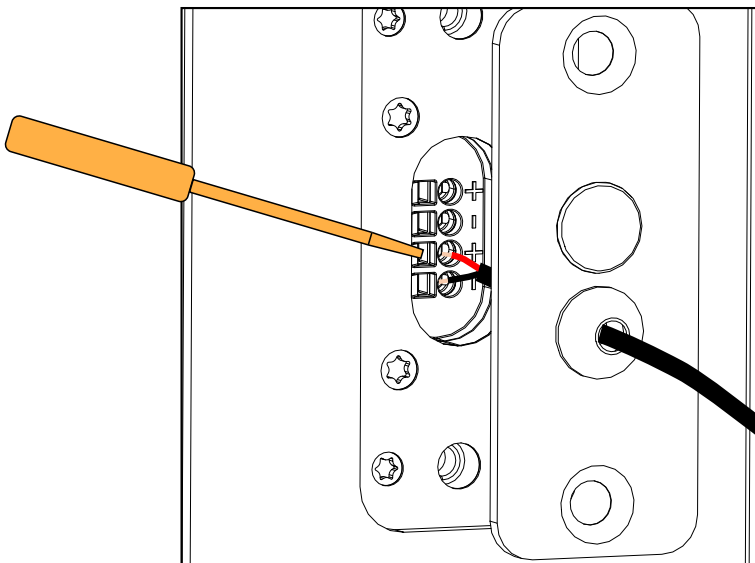



# Specifications

## Soka specifications

<b>Description</b>	2-way passive colinear enclosure: 9 × 3.5" LF + 3 × 1" HF diaphragm, amplified by LA2Xi / LA4X / LA7.16i / LA12X		
	with preset [SOKA_60]	with preset [SOKA]	with preset [SOKA_200]
<b>Usable bandwidth (-10 dB)</b>	60 Hz - 20 kHz	100 Hz - 20 kHz	200 Hz - 20 kHz
<b>Maximum SPL<sup>1</sup></b>	with LA2Xi (bridge mode) / LA4X / LA7.16i / LA12X	124 dB	130 dB
	with LA2Xi	124 dB	128 dB
<b>Nominal directivity (-6 dB)</b>	vertical: +5/-21° (> 2 kHz) horizontal: 140°		
<b>Transducers</b>	LF: 9 × 3.5" neodymium cone driver HF: 3 × 1" neodymium		
<b>Acoustical load</b>	LF: closed enclosure HF: conical waveguide, L-Fins		
<b>Nominal impedance</b>	8 Ω		
<b>Connectors</b>	1 × 4-point terminal block with push-in connection		
<b>Rigging and handling</b>	6 M6 inserts for external rigging and safety		
<b>Weight (net)</b>	9.4 kg / 20.7 lb		
<b>Cabinet</b>	premium grade Baltic beech and birch plywood		
<b>Front</b>	coated steel grill acoustically neutral 3D fabric		
<b>Finish</b>	dark grey brown Pantone 426 C pure white RAL 9010 custom RAL code on special order		
<b>IP</b>	IP55		

<sup>1</sup> Peak level measured at 1 m under free field conditions using pink noise with crest factor 4 (preset specified in brackets).

## Soka dimensions

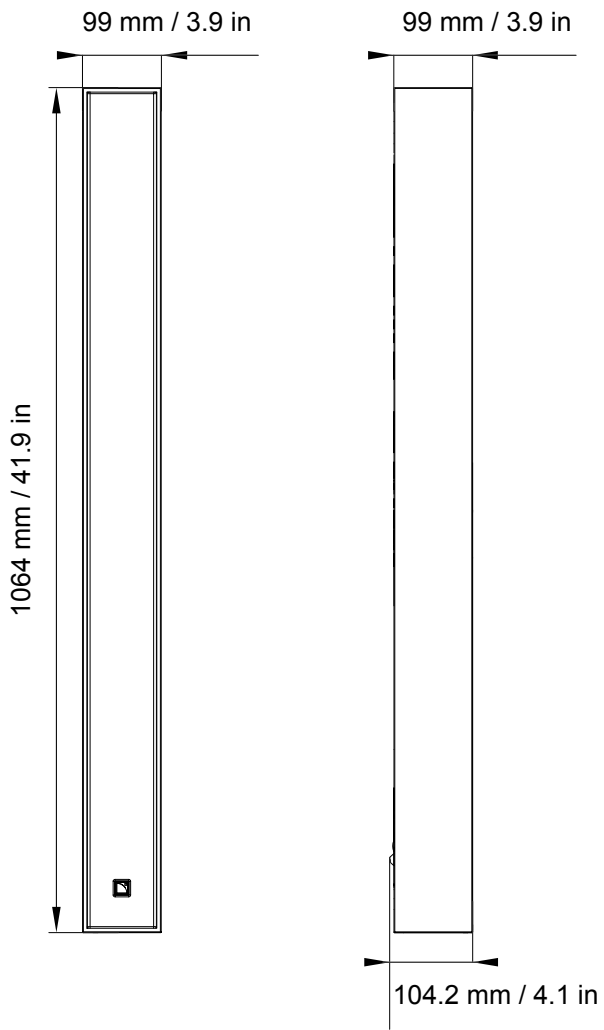

## SB6i specifications

<b>Description</b>	Ultra-shallow subwoofer: 2 × 6.5", amplified by LA2Xi / LA4X / LA7.16i / LA12X		
	with preset [SB6_60]	with preset [SB6_100]	with preset [SB6_200]
<b>Low frequency limit (-10 dB)</b>	29 Hz	29 Hz	32 Hz
<b>Maximum SPL<sup>1</sup></b>	110 dB	111 dB	115 dB
<b>Nominal directivity (-6 dB)</b>	standard configuration		
<b>Transducers</b>	2 × 6.5" cone driver		
<b>Acoustical load</b>	bass-reflex, L-Vents		
<b>Nominal impedance</b>	4 Ω		
<b>Connectors</b>	1 × 4-point terminal block with push-in connection		
<b>Rigging and handling</b>	8 M6 inserts for rigging accessories		
<b>Weight (net)</b>	8.6 kg / 19 lb		
<b>Cabinet</b>	premium grade Baltic beech and birch plywood		
<b>Front</b>	coated steel grill acoustically neutral 3D fabric		
<b>Finish</b>	dark grey brown Pantone 426 C pure white RAL 9010 custom RAL code on special order		
<b>IP</b>	IP55		

<sup>1</sup> Peak level at 1 m under half space conditions using pink noise with crest factor 4 (preset specified in brackets).

## SB6i dimensions

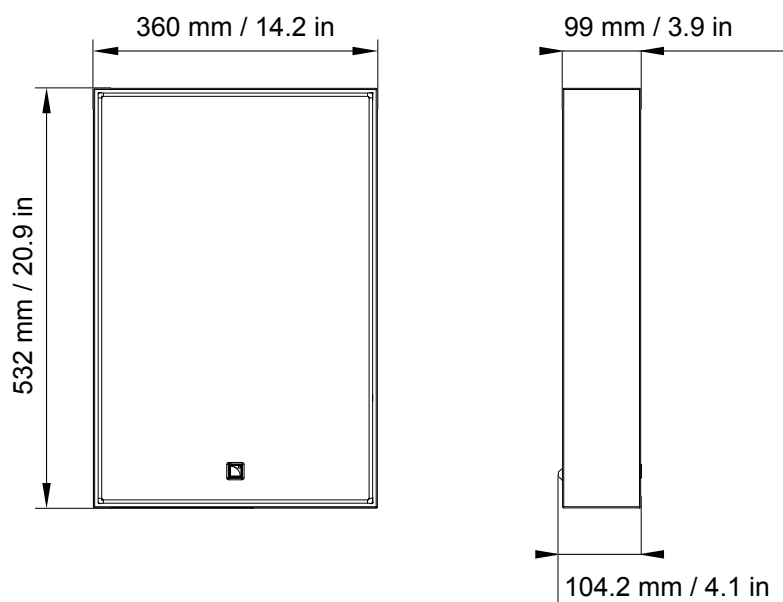

## SB10i specifications

Description	Ultra-compact subwoofer: 1 × 10" (installation version), amplified by LA2Xi / LA4X / LA7.16i / LA12X		
	with [SB10_60]	with [SB10_100]	with [SB10_200]
<b>Low frequency limit (-10 dB)</b>	25 Hz	27 Hz	29 Hz
<b>Maximum SPL<sup>1</sup></b> with LA2Xi (bridge mode) / LA4X / LA7.16i / LA12X	119 dB	122 dB	124 dB
with LA2Xi	119 dB	120 dB	122 dB
<b>Nominal directivity (-6 dB)</b>	standard configuration		
<b>Transducers</b>	1 × 10" cone driver		
<b>Acoustical load</b>	bass-reflex, L-Vents		
<b>Nominal impedance</b>	8 Ω		
<b>Connectors</b>	1 × 4-point terminal block with push-in connection		
<b>Rigging and handling</b>	12 M6 inserts for rigging accessories		
<b>Weight (net)</b>	14 kg / 31 lb		
<b>Cabinet</b>	premium grade Baltic birch plywood		
<b>Front</b>	coated steel grill		
	acoustically neutral 3D fabric		
<b>Finish</b>	dark grey brown Pantone 426 C		
	pure white RAL 9010		
	custom RAL code on special order		
<b>IP</b>	IP55		

<sup>1</sup> Peak level at 1 m under half space conditions using pink noise with crest factor 4 (preset specified in brackets).

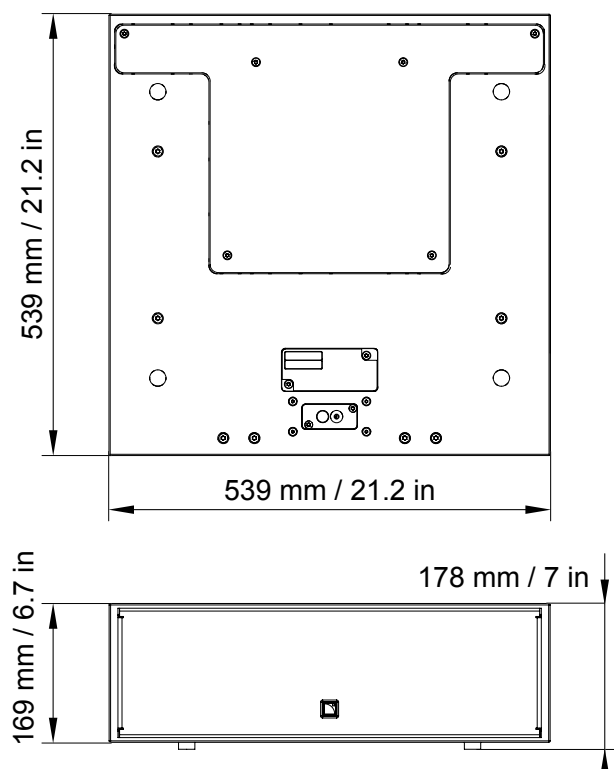
**SB10i dimensions**

## Soka-onW specifications

---

<b>Description</b>	On-wall mounting accessory for Soka
<b>Weight (net)</b>	0.36 kg / 0.79 lb
<b>Material</b>	high grade steel with anti-corrosion coating

### Soka-onW dimensions

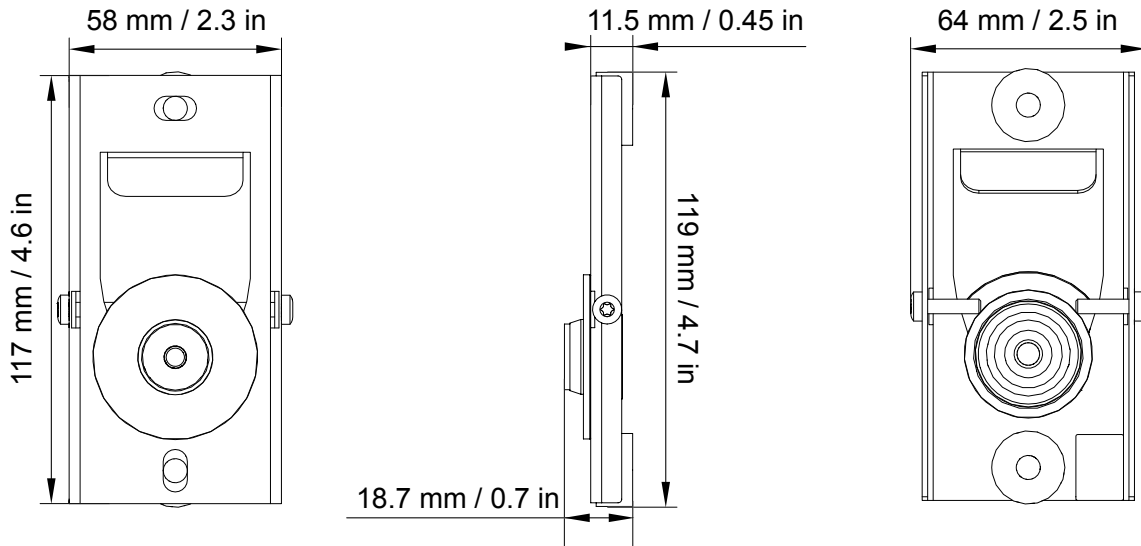

## Recommendation for speaker cables

Follow the recommended maximum length for loudspeaker cables to ensure minimal SPL attenuation.



### Cable quality and resistance

Only use high-quality fully insulated speaker cables made of stranded copper wire.

Use cables with a gauge offering low resistance per unit length and keep the cables as short as possible.

The table below provides the recommended maximum length for loudspeaker cables depending on the cable gauge and on the impedance load connected to the amplifier.

cable gauge			recommended maximum length					
			8 Ω load		4 Ω load		2.7 Ω load	
mm <sup>2</sup>	SWG	AWG	m	ft	m	ft	m	ft
2.5	15	13	30	100	15	50	10	33
4	13	11	50	160	25	80	17	53
6	11	9	74	240	37	120	25	80

Use the more detailed L-Acoustics calculation tool to evaluate cable length and gauge based on the type and number of enclosures connected. The calculation tool is available on our website:

<https://www.l-acoustics.com/installation-tools/>

## Specifications for custom rigging

### Dimensions

Refer to [Soka dimensions](#) (p.34).

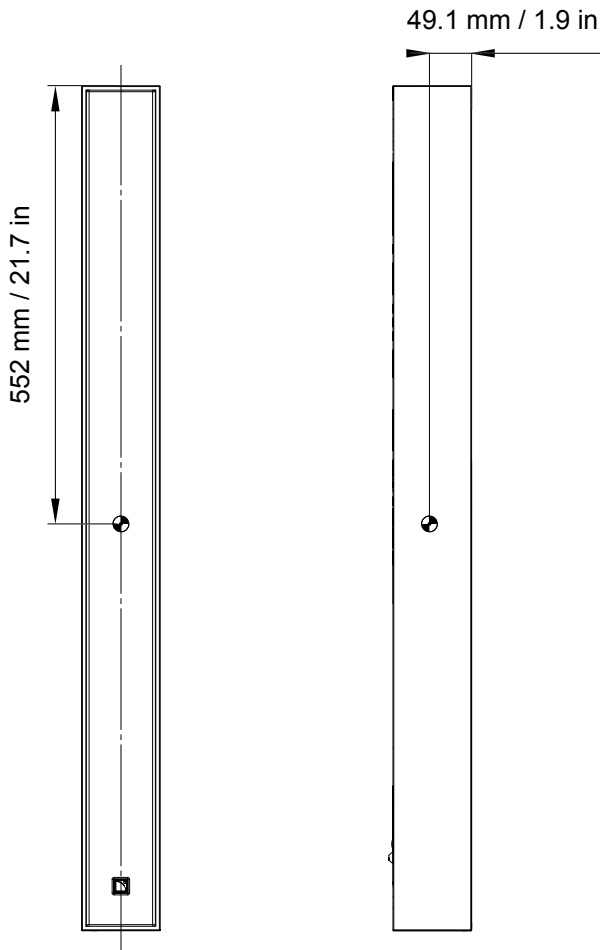

### Center of gravity



### Weight

Soka: 9.4 kg / 20.7 lb

### Threaded inserts and screws

- ⚠ Use only rigging inserts to implement a custom rigging**  
Inserts marked with  can be used for rigging.  
Inserts marked with  must not be used for custom rigging (reserved for screen mounting, maintenance purposes, L-Acoustics accessories, etc.).
- ⚠ Grade of screws must be defined by a qualified person**  
Take into consideration the number of inserts used, weight and center of gravity of enclosure(s), and resulting action forces.  
Prevent screws from loosening (threadlocker, spring washer...).



Soka has **9 threaded M6 inserts** available for rigging.

Ultimate Tensile Strength	1160 N
Ultimate Shear Strength	3300 N
Recommended screw length *	min. 20 mm / 0.8 in
Recommended torque	5 N.m

**i** \* Recommended screw length for a metal sheet with a thickness of 3 mm / 0.1 in. Adapt the length to the custom rigging design.

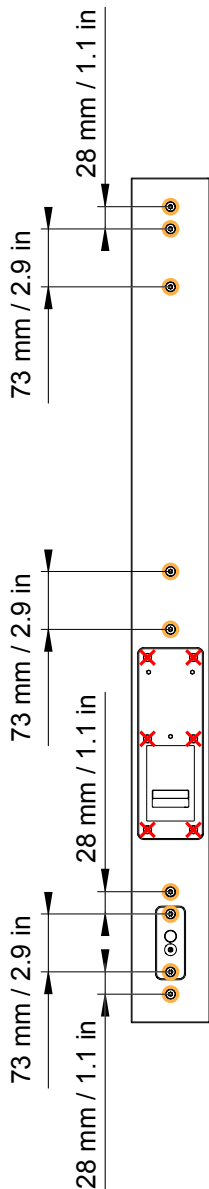



**L-Acoustics**

13 rue Levacher Cintrat - 91460 Marcoussis - France  
+33 1 69 63 69 63 - [info@l-acoustics.com](mailto:info@l-acoustics.com)  
[www.l-acoustics.com](http://www.l-acoustics.com)

 **L-ACOUSTICS**  
GROUP